



IOWN
GLOBAL FORUM™

Fiber Sensing for Open APN

– Technology Gaps and Potential Solutions

Classification: APPROVED REFERENCE DOCUMENT

Confidentiality: PUBLIC

Version 2

February 2023

[OAF]

Legal

THIS DOCUMENT HAS BEEN DESIGNATED BY THE INNOVATIVE OPTICAL AND WIRELESS NETWORK GLOBAL FORUM, INC. (“IOWN GLOBAL FORUM”) AS AN APPROVED REFERENCE DOCUMENT AS SUCH TERM IS USED IN THE IOWN GLOBAL FORUM INTELLECTUAL PROPERTY RIGHTS POLICY (THIS “REFERENCE DOCUMENT”).

THIS REFERENCE DOCUMENT IS PROVIDED “AS IS” WITH NO WARRANTIES WHATSOEVER, WHETHER EXPRESS, IMPLIED, STATUTORY, OR OTHERWISE, INCLUDING WITHOUT LIMITATION ANY WARRANTY OF MERCHANTABILITY, NONINFRINGEMENT OF THIRD PARTY RIGHTS, TITLE, VALIDITY OF RIGHTS IN, FITNESS FOR ANY PARTICULAR PURPOSE, OR ANY WARRANTY OTHERWISE ARISING OUT OF ANY PROPOSAL, REFERENCE DOCUMENT, SAMPLE, OR LAW. WITHOUT LIMITATION, IOWN GLOBAL FORUM DISCLAIMS ALL LIABILITY, INCLUDING WITHOUT LIMITATION LIABILITY FOR INFRINGEMENT OF ANY PROPRIETARY RIGHTS AND PRODUCTS LIABILITY, RELATING TO USE OF THE INFORMATION IN THIS REFERENCE DOCUMENT AND TO ANY USE OF THIS REFERENCE DOCUMENT IN CONNECTION WITH THE DEVELOPMENT OF ANY PRODUCT OR SERVICE, AND IOWN GLOBAL FORUM DISCLAIMS ALL LIABILITY FOR COST OF PROCUREMENT OF SUBSTITUTE GOODS OR SERVICES, LOST PROFITS, LOSS OF USE, LOSS OF DATA OR ANY INCIDENTAL, CONSEQUENTIAL, DIRECT, INDIRECT, PUNITIVE, EXEMPLARY, OR SPECIAL DAMAGES, WHETHER UNDER CONTRACT, TORT, WARRANTY OR OTHERWISE, ARISING IN ANY WAY OUT OF USE OR RELIANCE UPON THIS REFERENCE DOCUMENT OR ANY INFORMATION HEREIN.

EXCEPT AS EXPRESSLY SET FORTH IN THE PARAGRAPH DIRECTLY BELOW, NO LICENSE IS GRANTED HEREIN, EXPRESS OR IMPLIED, BY ESTOPPEL OR OTHERWISE, TO ANY INTELLECTUAL PROPERTY RIGHTS OF THE IOWN GLOBAL FORUM, ANY IOWN GLOBAL FORUM MEMBER OR ANY AFFILIATE OF ANY IOWN GLOBAL FORUM MEMBER. EXCEPT AS EXPRESSLY SET FORTH IN THE PARAGRAPH DIRECTLY BELOW, ALL RIGHTS IN THIS REFERENCE DOCUMENT ARE RESERVED.

A limited, non-exclusive, non-transferable, non-assignable, non-sublicensable license is hereby granted by IOWN Global Forum to you to copy, reproduce, and use this Reference Document for internal use only. You must retain this page and all proprietary rights notices in all copies you make of this Reference Document under this license grant

THIS DOCUMENT IS AN APPROVED REFERENCE DOCUMENT AND IS SUBJECT TO THE REFERENCE DOCUMENT LICENSING COMMITMENTS OF THE MEMBERS OF THE IOWN GLOBAL FORUM PURSUANT TO THE IOWN GLOBAL FORUM INTELLECTUAL PROPERTY RIGHTS POLICY. A COPY OF THE IOWN GLOBAL FORUM INTELLECTUAL PROPERTY RIGHTS POLICY CAN BE OBTAINED BY COMPLETING THE FORM AT: www.iowngf.org/join-forum. USE OF THIS REFERENCE DOCUMENT IS SUBJECT TO THE LIMITED INTERNAL-USE ONLY LICENSE GRANTED ABOVE. IF YOU WOULD LIKE TO REQUEST A COPYRIGHT LICENSE THAT IS DIFFERENT FROM THE ONE GRANTED ABOVE (SUCH AS, BUT NOT LIMITED TO, A LICENSE TO TRANSLATE THIS REFERENCE DOCUMENT INTO ANOTHER LANGUAGE), PLEASE CONTACT US BY COMPLETING THE FORM AT: <https://iowngf.org/contact-us/>

Copyright © 2023 Innovative Optical Wireless Network Global Forum, Inc. All rights reserved. Except for the limited internal-use only license set forth above, copying or other forms of reproduction and/or distribution of this Reference Document are strictly prohibited.

The IOWN GLOBAL FORUM mark and IOWN GLOBAL FORUM & Design logo are trademarks of Innovative Optical and Wireless Network Global Forum, Inc. in the United States and other countries. Unauthorized use is strictly prohibited. IOWN is a registered and unregistered trademark of Nippon Telegraph and Telephone Corporation in the United States, Japan, and other countries. Other names and brands appearing in this document may be claimed as the property of others.

Contents

1. Introduction 5

 1.1. Overview of Release 1.0 and positioning of Release 2.0 5

 1.2. Purpose of the document 8

2. Interrogator 9

 2.1. Total power and peak power 9

 2.1.1. Type II-2 11

 2.1.2. Type III 11

 2.1.3. Evaluation method 12

 2.1.4. Influence of telecom light and installed fiber on sensing light 12

 2.1.5. Solutions 13

 2.2. Laser linewidth 13

 2.3. Bandwidth and wavelength tunable function 13

3. Sensing Fiber and Cable 15

 3.1. Gap analysis 16

 3.1.1. Type I 18

 3.1.2. Type II 18

 3.1.3. Type III 18

 3.2. Evaluation method 18

 3.3. Solutions 19

4. Connection to Open APN 20

 4.1. Open APN nodes-related fiber sensing architecture 20

 4.2. Technical gap of connection between APN-G and fiber sensing interrogator 20

 4.3. Examples of countermeasures for the technical gap of the connection between APN-G and fiber sensing interrogator 22

5. Data Channel 26

 5.1. “Remote control” and “data transmission” 26

 5.2. Patterns of “data transmission” 26

 5.3. Data capacity and bandwidth 27

 5.4. Data processing 28

 5.5. Latency 28

6. System Control 29

 6.1. Control mechanism 29

7. Conclusion 32
References 34
History 35

List of Figures

Figure 1-1 Fiber sensing architecture Type I 6
 Figure 1-2 Fiber sensing architecture Type II-1 6
 Figure 1-3 Fiber sensing architecture Type II-2 7
 Figure 1-4 Fiber sensing architecture Type III 7
 Figure 4-1 APN-G configuration with amplification 21
 Figure 4-2 Probe light from the interrogator to pass through multiple APN-Gs 22
 Figure 4-3 External switch dedicated to fiber sensing in the first stage for selecting each APN-G 23
 Figure 4-4 Configuration using circulator where backscattered light is inserted into APN-G through the circulator 24
 Figure 4-5 Configuration using circulator where backscattered light is inserted into APN-G through the circulator 24
 Figure 4-6 Configuration with couplers 25
 Figure 6-1 System control for telemetry 30
 Figure 6-2 System control for environmental sensing 31

List of Tables

Table 2-1 Gap analysis 9
 Table 2-2 Comparison of DFOS technologies (in FSOA 1.0) 10
 Table 3-1 Comparison of DFOS technologies (in FSOA 1.0) 17

1. Introduction

1.1. Overview of Release 1.0 and positioning of Release 2.0

In the Open APN Fiber Sensing Task Force (OAF-TF) of the IOWN Global Forum, for the realization of fiber sensing over future networks, the Open All-Photonics-Network (APN) is discussed. Fiber sensing technology at this Forum refers to Distributed Fiber Optic Sensing (DFOS), which is a technology for real-time, continuous, multi-point measurement of environmental conditions that change along an entire fiber optic cable with minute intervals between measurement points. DFOS systems monitor and quickly report environmental characteristics such as temperature, strain, and vibration (including acoustics) over long distances in a fiber-optic network with a spatial resolution on the order of meters. If such fiber sensing technology can obtain sensing data from fiber-based communication networks, it is expected to be useful in diverse fields, including traffic monitoring, earthquake detection, building health, and other applications not envisioned today. Additionally, some equipment between the transmission and sensing applications can be shared and much of the installed fiber can be noninvasively augmented to support sensing and therefore keep costs to a minimum.

In January 2022, a document entitled *Fiber Sensing for Open APN* [FSOA 1.0] was published to promote discussions on the realization of various applications by fiber sensing in such communication networks, especially in Open APNs. It was a technical document that described the benefits, basic technical features, and other challenges of fiber sensing in telecommunications networks and served as the basis for future discussions on the realization of fiber sensing over Open APNs.

The contents of FSOA 1.0 include various optical fiber sensing technologies classified according to the physical phenomena and quantities to be measured, current use cases, challenges, and conditions to coexist with communication transmission, especially for connecting architectures with Open APNs. The fiber sensing architecture types described in FSOA 1.0 are shown in Figure 1.1, 1.2, 1.3, and 1.4 and are called Type I, II-1, II-2, and III, respectively. The details of the Types are described in FSOA 1.0..

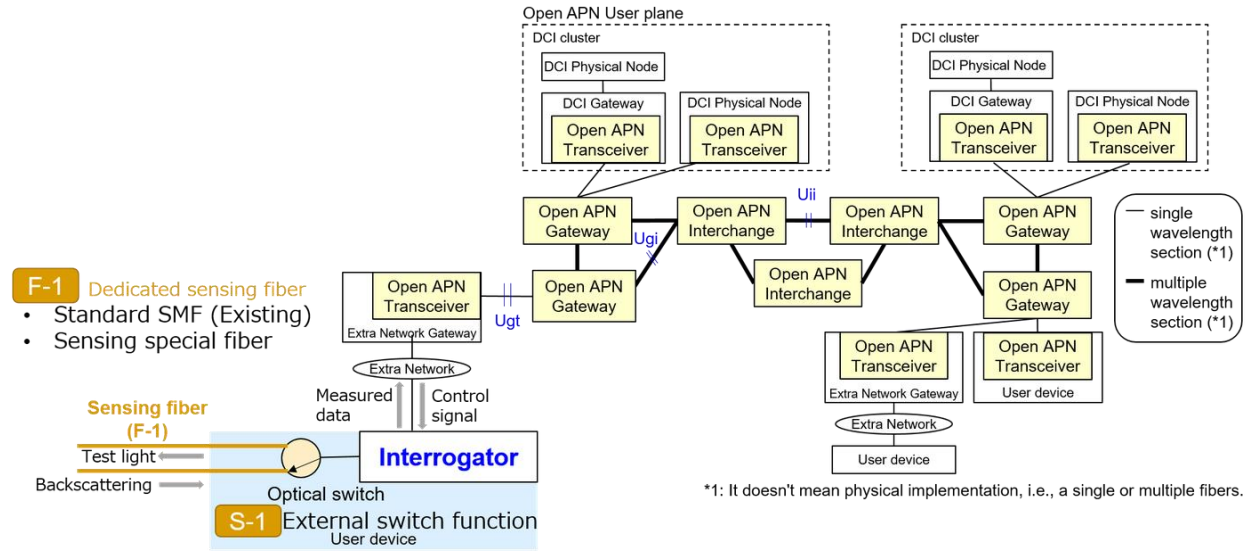

Figure 1-1 Fiber sensing architecture Type I

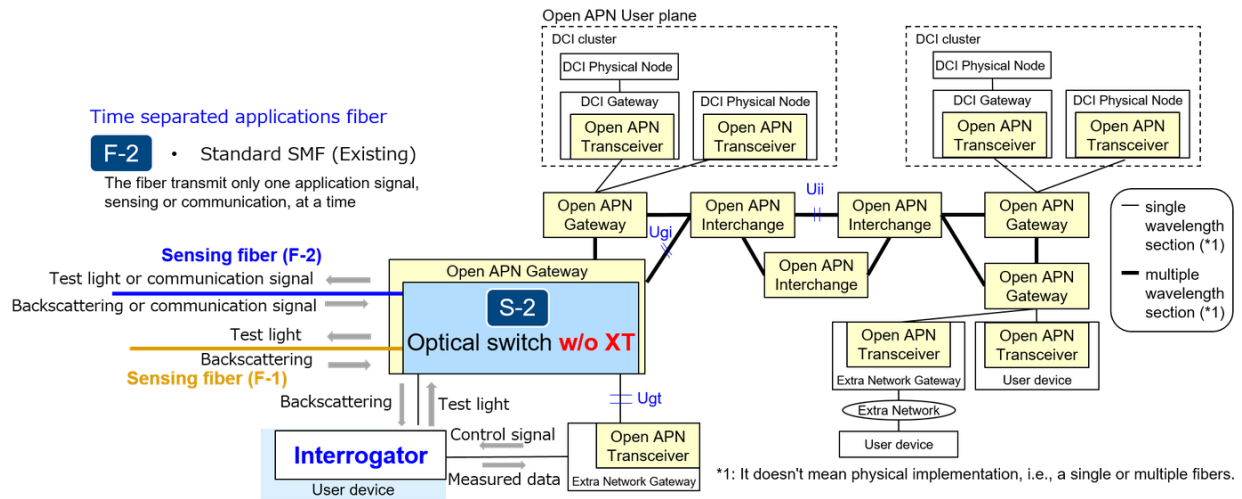

Figure 1-2 Fiber sensing architecture Type II-1

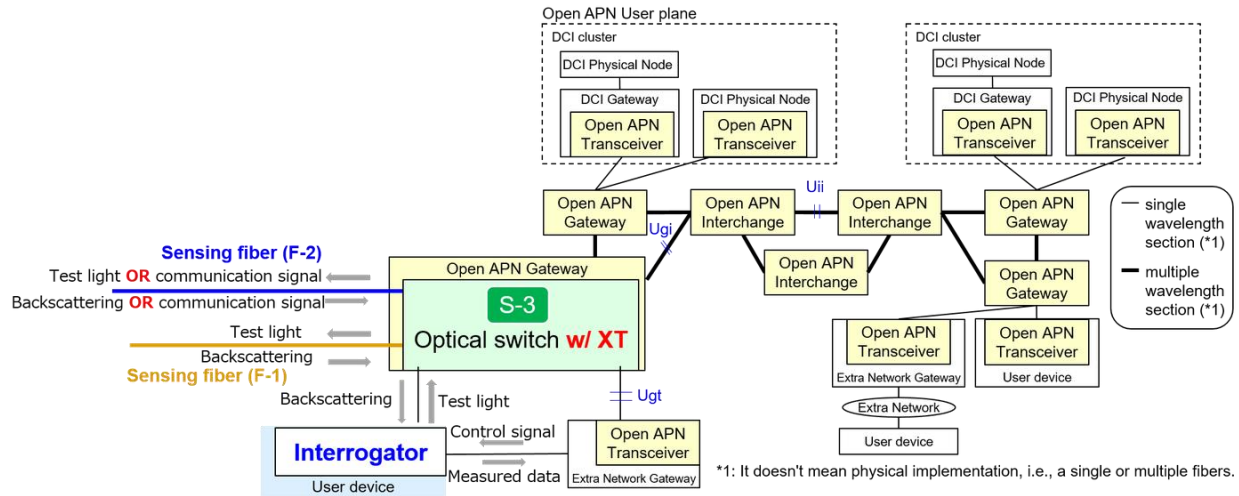

Figure 1-3 Fiber sensing architecture Type II-2

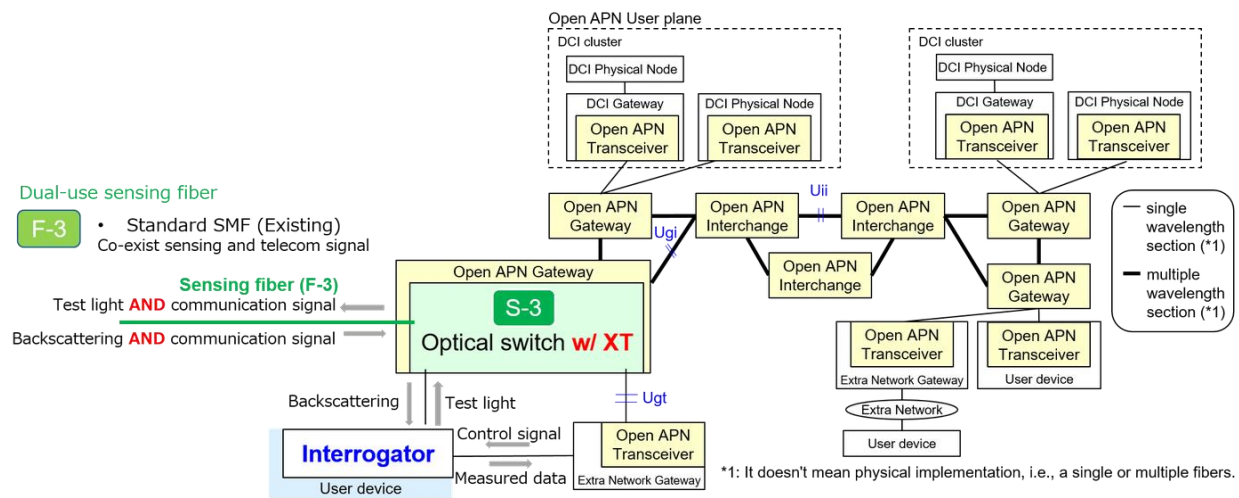

Figure 1-4 Fiber sensing architecture Type III

Based on FSOA 1.0, in 2022, OAF-TF has been discussing solutions for technical gaps and commercial-based technologies to actualize fiber sensing over Open APNs. This document is a sequel to FSOA 1.0. In this document, the technical gaps and solutions of each technical element in fiber sensing over Open APNs are described. In particular, the technical gaps between the sensing architecture described in FSOA 1.0 and commercial products will be documented and possible solutions when implementing fiber sensing functions in Open APNs are presented.

1.2. Purpose of the document

This document clarifies the direction of consideration for implementing fiber sensing at Open APNs as described in FSOA 1.0. That is, this document is aiming to encourage various players to study diverse and specific solutions for fiber sensing over Open APN.

By clarifying gaps that are not resolved with current commercial-based technologies, it is expected that discussions on countermeasures and alternatives to unexamined, immature, and unproven technological gaps can be advanced. Moreover, based on this information, verification, and trials to confirm feasibility are possible.

For this purpose, the following describes in detail the technical gaps and solution examples of each technical element in fiber sensing over Open APN. Section 2 describes interrogators, Section 3 describes sensing fibers and cables, Section 4 describes connections to Open APN nodes, Section 5 describes transfer data channels, Section 6 describes system controls, and Section 7 provides a conclusion statement.

Similar to FSOA 1.0, this document does not aim to discuss the detailed fiber optic sensing principles nor develop novel fiber optic sensing technologies, since fiber optic sensing technologies are quite diverse, and different manufacturers might adapt different types of sensing method or different variants of technology, including proprietary ones. Therefore, instead of specific fiber sensing technologies, this document focuses on the integration of fiber optic sensing functionality into Open APN, with the target of achieving fast and seamless realization of such integration so that the Open APN can deliver the additional function and value of sensing over the network.

2. Interrogator

This section describes the gap analysis between the FSOA 1.0 and its realization with Open APN is described. The result of the analysis is summarized in Table 2.1. In the Open APN with fiber sensing, since both the sensing light and the telecom data propagate in the same optical fiber, it is necessary to prevent the degradation of transmission quality of the telecom data. From the fiber sensing point of view, it is also necessary to select a wavelength and bandwidth that meet the requirements of the telecom network. In order to apply sensing technology to Open APN, it is desirable to clarify how the interrogator affects the telecom data and specify the recommended optical characteristics of the interrogator.

Table 2-1 Gap analysis

		TYPE I	TYPE II-2	TYPE III	COMMENTS
Interrogator	Total power	-	○	○	Crosstalk, fiber nonlinearity
	Peak power	-	○	○	Crosstalk, fiber nonlinearity
	Laser linewidth	-	-	○	Crosstalk, fiber nonlinearity
	Bandwidth	-	-	○	Within ITU-grid?
	Wavelength tunable function	-	-	○	On ITU-grid?, tunable LD, filter

2.1. Total power and peak power

Since Type I uses a dedicated fiber for sensing, telecom and sensing are independently performed without possibility for conflict. Therefore, no evaluation of total power and peak power would be necessary. Type II divides the telecom light and the sensing light either in time or in separate optical fibers. Type II is further divided into two cases, Type II-1 and Type II-2. In the Type II-1, the fiber switch function (such as wavelength selective switch [WSS]) in Open APN has no crosstalk. Therefore, Type II-1 also needs not be evaluated for power like Type I. Type II-2 is expected to use a fiber switch with crosstalk. Furthermore, in Type III, telecom light and sensing light propagate through the same fiber channel at the same time. Therefore, it is necessary to evaluate the effect of crosstalk in Type II-2 and Type III.

Table 2.2 shows typical values for various DFOS technologies summarized in FSOA 1.0. As shown in this table, peak powers for vibration-, temperature-, and strain-sensing are larger than that of traditional OTDRs that are used to detect fiber cut and attenuation. Since R-OTDR requires a large peak power of 1W class, crosstalk evaluation will be necessary. The crosstalk phenomena assumed for Type II-2 and Type III are described below:

Table 2-2 Comparison of DFOS technologies (in FSOA 1.0)

SENSING TECHNOLOGY		OTDR	DWDM-OTDR	C-OTDR	OFDR	B-OTDR	R-OTDR
Backscattering		Rayleigh			Brillouin		Raman
Application		Fiber cut and attenuation		Vibration / acoustic	Strain / Temperature / Vibration	Strain / Temperature	Temperature
Probe laser light* (forward)	Center wavelength [nm]	1550.12 nm	DWDM grid	1550.12 nm *typical			
	Laser spectral linewidth	No restriction, but usually use LDs with 1MHz to 10MHz		<= ~1 kHz		~1 MHz	No restriction
	Laser output power P_{in}	>=4mW peak		100~200 mW peak	Tens of mW	100~200 mW peak	>= 1W peak
	Pulse / CW	Pulse, pulse width: 10-200ns		Pulse, pulse width: ~50 ns	Frequency modulated CW	Pulse, pulse width: ~50 ns	Pulse, pulse width: ~10 ns
	Signal bandwidth (FWHM)	Inverse of the pulse width: 5~100 MHz		Inverse of the pulse width: ~20 MHz	Frequency modulation bandwidth	Inverse of the pulse width: ~20 MHz	Inverse of the pulse width: ~100 MHz
Backscattering* (reverse)	Analyzed signal	Intensity		Phase or intensity	Scattered field over optical spectrum	Brillouin frequency shift	Raman intensity
	Detected signal power	About 42 dB lower than P_{in}				About 50 dB lower than P_{in}	About 70 dB lower than P_{in}

	Signal bandwidth (FWHM)	Same as probe signal bandwidth	~±11 GHz	± 100 nm
--	-------------------------	--------------------------------	----------	----------

* Typical values

2.1.1. Type II-2

Type II-2 is a time-division application where sensing light and telecom light do not propagate in the same fiber channel at the same time. In this case, since there is no interaction in fiber channel, the impact of non-linear effects may be negligible. However, with the fiber switching function (such as WSS), many telecom light (WDM) channels and sensing photons propagate concurrently. Therefore, crosstalk in power may be problematic. When the fiber switching function is WSS the crosstalk depends on wavelength filtering characteristics of the WSS between adjacent wavelength bands. Regarding the power transmission characteristics of the fiber switching function, it is necessary to evaluate both the effect of the sensing light on the telecom signals and the effect of the telecom signals on the sensing light.

2.1.2. Type III

In Type III, telecom light and sensing light propagate through the same fiber channel. When the propagations of telecom and sensing light are in the same direction, it is necessary to evaluate the effect of cross-phase modulation (XPM) and four-wave mixing (FWM) on the system’s fiber sensing capabilities.

XPM is a phenomenon in which the phase of the propagating light changes according to the power of coexisting light due to the optical Kerr effect when two coherent light waves with different wavelengths propagate through the same fiber. Therefore, the phases of the sensing light and the telecom light are modulated according to their relative powers. When the telecom light and the sensing light propagate in the same direction in the fiber channel, the interaction elongates axially. Therefore, the XPM effect may appear even with a peak power of several tens of mW.

FWM is a type of optical Kerr effect that occurs when two or more different wavelengths of light enter a fiber. In general, when light with three different wavelengths are coupled to an optical fiber, new light is generated at a wavelength that does not match any of the three wavelengths. The errant light is called idler light. Since idler light may affect telecom light it is necessary to evaluate the FWM effect.

In OTDRs, the time duty of the pulse is larger than the bit period of the telecom signal. Therefore, the high-power CW light of the OTDR simultaneously coexists along with the telecom signal and the FWM may need to be evaluated.

2.1.3. Evaluation method

The evaluation methods under consideration are the following. Type II-2 and III, APN-G including optical switch with crosstalk are assumed. The sensing light and telecom signal are coupled to the optical fiber at the same time. The degree of deterioration in quality of the telecom signal (for example, bit error rate) is evaluated in terms of the peak power, total power (depending on the pulse width), and pulse period (depending on the measurement distance). Similarly, for Type III, the sensing light and the telecom signal enter the optical fiber by wavelength-division multiplexing, and the quality of the telecom signals are evaluated as described above. Although there are various DFOS technologies listed in Table 2.2, for simple evaluation, common optical pulse generation technique with variable peak powers, repetition rates, and pulse widths may be used similarly. Crosstalk of the fiber switching function depending on the wavelength of sensing light is also evaluated. When WSS is used as the fiber switching function since the transmission characteristic of the WSS and the effect of XPM depend on the wavelength spacing of the two light waves, it is also important to evaluate crosstalk with the wavelength spacing as a variable.

2.1.4. Influence of telecom light and installed fiber on sensing light

The power of Rayleigh, Brillouin, and Raman scattered light is 40, 50, and 70 dB lower than the input power, respectively. Therefore, a small amount of idler light due to FWM may affect the measurement of scattered light. Since R-OTDR is based on the observation of the intensity of Stokes and anti-Stokes light, even if the power of the idler is small, the accuracy of the sensing temperature may fluctuate.

The XPM effect causes phase modulation. In general, since C-OTDR and B-OTDR observe the phase and frequency shift of backscattered light, respectively, it is desirable to investigate the effect of XPM on sensing quality when sensing light and telecom light propagate in the same direction.

Additionally, when using installed fiber for sensing, the point of splicing and connector connection depends on the fiber channel. Since the power of the scattering light depends on such splicing and connector connections, the interrogator should calibrate the power

distribution channel-by-channel for R-OTDR. In this respect, since C-OTDR and B-OTDR observe phase and frequency shifts, respectively, interrogator requirements for arbitrary channel measurements are relaxed.

2.1.5. Solutions

In Type II-2 and Type III, if crosstalk cannot be ignored, two solutions are possible. One solution is to reduce the power of the sensing light to the level where the influence on the communication quality is negligible at the expense of the measurement range of the sensing. The other solution is to strategically separate the wavelengths of the sensing light and the telecom light so that they do not affect each other. The simplest method is to fix the wavelength of the sensing light to an unused wavelength band in communication. It is also possible to adaptively control the wavelengths used by negotiating with the control plane. However, this modifies the network architecture and complicates the entire system.

2.2. Laser linewidth

Since an extremely narrow linewidth laser (~1 kHz) is used, the evaluation of fiber nonlinearities such as Stimulated Brillouin Scattering effects on the telecom signal may be necessary, particularly due to vibration sensing. On the other hand, the effect of Brillouin scattering is about 10.9 GHz with respect to the center wavelength of the laser. Therefore, since Brillouin scattering generated by the sensing light is within the WDM grid, its effect is expected to be minor. If the effect on communication quality is significant, one possible solution is to set the center wavelength of the sensing light rigorously so that the wavelength of Brillouin scattering does not reach other WDM grids. As in sub-section 2.1, it is also effective to fix the sensing wavelength to an unused wavelength band in communication.

For further investigation, it may be suitable to evaluate the effect on the telecom signal by using various laser linewidths with numerous wavelength separations.

2.3. Bandwidth and wavelength tunable function

In a Type III architecture, the telecom signal and sensing light propagate through the optical fiber simultaneously. As shown in Table 2.2, the bandwidth of the probe light depends on the sensing principle employed. For example, in DAS, multi-wavelength

methods may be employed to eliminate fading effect or to improve the SNR. In the WDM network, spectral grid is provided by ITU-T. To use such sensing light together with telecom signals, it may be necessary to specify the center wavelength and bandwidth according to the ITU grid.

In addition, depending on the network architecture of Open APN, a wavelength tunable function may be required from the interrogator. According to commands from the control plane the interrogator flexibly changes the center wavelength of the probe light. For such switching functionality we continue discussions of Open APN network architectures. However, providing an interrogator with a narrow line width (<1kHz) light source and a variable center wavelength covering the C / L bands will lead to a significant cost increase.

3. Sensing Fiber and Cable

In this section, we describe a gap analysis between the fiber sensing for Open APN 1.0 and its realization with Open APN. In practice, sensing systems are commonly designed to operate over optical fiber and fiber-optic cable containing standard single-mode fiber based around the ITU-T G.694.1 grid. This ensures interoperability with installed and planned fiber-optic cabling globally. However, gaps do exist in our understanding and planning for use of sensing systems in concert with telecommunications systems, and their function over the same fibers within optical fiber cables. Furthermore, significant developments in terms of enhanced sensing capabilities are ongoing and this forum wishes to ensure that future incorporation of sensing on telecommunication networks accommodates for such sensing enhancements. To that end, this forum created Type I, Type II, and Type III scenarios whereby sensing is considered as an overlay to telecommunications use.

Type I: this method requires that the telecommunications system dedicate a fiber for sensing. This is most common and the traditional approach. When using this architecture there is no interference between the telecommunications activities and sensing activities, but a single fiber must be dedicated to sensing and therefore not available for use in telecommunications. Dedicated fiber could be a standard telecom-grade single-mode or an “enhanced single-mode” for improved systems-level sensitivity.

Type II: this method can be configured as Type I with a dedicated fiber for sensing and all other fibers within a cable for telecommunications. The dedicated fiber could be a standard telecom-grade single-mode or an “enhanced single-mode” for improved systems-level sensitivity.

Type II adds the option of invoking signal timing (alternating timing of telecom transmission and sensing laser pulses) to enable an optical fiber to transmit telecommunication signals while also being used for sensing applications. Time separation of transmission and sensing signals would eliminate crosstalk between applications.

Type III: this method is the most complex approach whereby telecommunications pulses and sensing pulses occur simultaneously within a single fiber – therefore crosstalk between applications must be studied and accommodations made to ensure that the telecommunications and sensing application can run concurrently without compromising the performance of either system. This fiber could be a standard telecom-grade single-mode or an “enhanced single-mode” for improved systems-level sensitivity.

We note that telecom links can include many types of transmission fibers such as graded index multimode fibers (G.651), and various single-mode fibers G.652, G.653, G.654, G.655, G.656, G.657. These fiber types vary in their mode field diameter, single-mode cut-off wavelength, bend loss, chromatic dispersion, polarization mode dispersion, and attenuation. While G.652 and G.657 are most common in modern networks, legacy fiber types also exist in active networks. Any sensing scheme that uses the installed base of fibers must specify which fiber types it is applicable to. For multimode fiber (G.651), the link length is typically much shorter, however such fibers can also be used for sensing. These fibers are typically deployed in data centers, multiple dwelling units (MDUs) and industrial settings, all of which benefit from sensing applications.

Recent developments in optical fibers have led to the fabrication of hollow core fibers (HCFs) and multicore fibers. With HCF technologies, air is the transmission medium whereby the optical fibers are designed to include glass cladding regions around empty pathways to minimize propagation delays due to materials interaction that occur within the doped silica cores of traditional optical fibers. Such HCF fiber structures are emerging for low-latency transmission. In the case of MCF, numerous doped silica cores are included within the optical fibers to provide more pathways to carry laser transmission signals. Doing so may provide for increased cumulative bandwidth for such fibers and/or a reduction in physical space to accommodate needs for increases in anticipated bandwidth in cramped communications cables and/or pathways and ducts. While such fibers can also be used for sensing and telecom, they are not sufficiently developed to be within the scope of the present document.

3.1. Gap analysis

As depicted in table 3.1, numerous forms of distributed fiber-optic sensing are possible by coupling sensor interrogator equipment to optical fibers within existing and planned fiber-optic cables. This is akin to connecting an Optical Time Domain Reflectometer (OTDR), a common tool that relies on Rayleigh backscatter to assess attenuation and cable performance. Advanced equipment for sensing includes similar equipment designed to use backscatter in the detection of strain, temperature, or vibration as shown in Table 3.1. Such interrogator equipment provides the foundation for future activities, including structural health monitoring of civil projects and infrastructure, third-party intrusion detection to enhance safety and prevent crimes, and advanced vibration sensing for detection of other forms of intrusion such as tunneling. This technology could also add the capability to monitor seismic activity for early detection and warning of geophysical events.

Table 3-1 Comparison of DFOS technologies (in FSOA 1.0)

SENSING TECHNOLOGY		OTDR	DWD M-OTDR	C-OTDR	OFDR	B-OTDR	R-OTDR	SPAN LENGTH	FIBER CHARACTERISTICS
Backscattering		Rayleigh				Brillouin	Raman	< 100 km	Attenuation, MPI
Distributed Fiber-optic Sensing (DFOS) Application				Distributed Acoustic Sensing (DAS)		Distributed Strain and/or Temperature Sensing (DTSS also known as DSTS)	Distributed Temperature Sensing (DTS)	5-100 km	Attenuation, MPI
Application		Fiber cut and attenuation		Vibration / acoustic	Strain / Temperature / Vibration	Strain / Temperature	Temperature		
	Center wavelength [nm]	1550.12 nm	DWD M grid	1550.12 nm *typical					
Backscattering* (reverse)		Analyzed signal	Intensity	Phase or intensity	Scattered E field over optical spectrum	Brillouin frequency shift	Raman intensity	5-100 km	Attenuation
Standard Single-mode fibers (Ref. ITU-T G.694.1)		Suitable		Suitable	Suitable	Strain & Temperature	Suitable	> 60 km	Attenuation
Enhanced Single-mode fibers		Suitable		Greater Sensitivity	Greater Sensitivity	Strain & Temperature	Suitable	TBD	Attenuation, MPI
Standard Configuration Cable		Suitable		Suitable	Suitable	NA	Suitable	> 60 km	Attenuation

Enhanced Configuration	Cable	Suitable	Greater Sensitivity	Greater Sensitivity	Strain & Temperature	Suitable	TBD	Attenuation, MPI
-------------------------------	--------------	----------	---------------------	---------------------	----------------------	----------	-----	------------------

3.1.1. Type I

For the type I configuration, a given optical fiber will have to be identified for the sensing function so that no telecom transmission signals would be sent through this fiber. Therefore, the cable design would have to include proper labeling for the sensor fiber. In the case of enhanced scattering fiber, the primary change is the addition of enhanced scattering fibers to cable installations. The enhanced backscattering fiber will have to satisfy the same optical and physical specifications as standard fiber. The fiber will also have to be labelled or otherwise identified to avoid its use in signal transmission.

3.1.2. Type II

For type II (applies to Type II-1, and II-2, see Section 2.1 for detailed explanation) all changes required for type I would be required. However, in addition to these changes, the sensor fiber would need to be designated as in-use either as a sensor or transmission fiber. If transmission signals are sent in the fiber, the attenuation of the enhanced fiber would have to be noted and included in link design.

3.1.3. Type III

For type III, all changes from type I would be required. In this case, the enhancement bandwidth would need to be adjusted so that signals could be propagated in the fiber without encountering a penalty. The fiber, within a cable, would also need to be labeled or otherwise identified to allow for proper link design.

3.2. Evaluation method

For type I and II, standard methods of link design and sensing configurations would be used for testing the link. For type III, sensor and transmission signals would have to be sent into the fiber at the same time to ensure that the link penalties still meet the requirements for both sensing and telecom transmission.

3.3. Solutions

Based on Table 3.1 (above), a pathway to successful solutions can be created and a roadmap developed. Notably, most sensing applications today invoke standard single-mode optical fiber and standard cable solutions to complete a systems-level design. Special care in cable design and placement is generally less challenging with systems intended to measure vibration (DAS), and temperature (DTS), however, special considerations are necessary when planning to detect strain events. When detecting strain, it is imperative that the sensing cable/fiber be as directly coupled to the asset being monitored as practical. In the case of vibration and temperature, proximity of the sensing cable to its target is important, whereby closer placement achieves improved sensitivity. Enhanced fibers can greatly relieve this limitation, allowing for more flexibility in sensor cable installation. In cases where proximity is difficult, enhanced optical fibers and/or enhanced optical fiber cables may be utilized. As a result, design rules for cable installation with enhanced fibers will be amended from the design rules for cables with only standard fibers present.

DAS – Proximity to test subject is important. Otherwise, DAS is forgiving in terms of fiber type and cable type. Significantly improved performance can be achieved through the use of enhanced optical fibers featuring increased Rayleigh backscatter. The gains in signal-to-noise achieved with enhanced fibers can be sufficiently large that the design rules for the deployment of enhanced fiber cables can be relaxed with respect to those for cables with telecom-grade fibers.

DTS – Proximity to the test subject is important.

Raman-based DTS relies upon the Stokes/Anti-stokes backscatter ratio and enables reporting of absolute temperature and is independent of cable configuration.

Brillouin-based DTS relies on Brillouin backscatter and a loose-tube cable configuration is necessary to decouple the sensing fiber within from strain-induced effects.

DSTS/DTSS - When deploying Brillouin-based DSTS, care must be taken to separate strain effects from temperature effects in systems readings. This is often achieved through a hybrid loose-tube/tight-tube cable design where the tight configuration reports combined strain and temperature effects while the loosely configured subunit decouples the sensor fiber from strain effects. Separated, accurate results for temperature and strain can then be calculated and reported by the interrogator unit.

4. Connection to Open APN

4.1. Open APN nodes-related fiber sensing architecture

In FSOA 1.0, 4 types of fiber sensing architecture, Type I, Type II -1, II -2, and Type -3, were shown as a form of implementing fiber sensing in the Open APN. They show a pattern of connecting fiber sensing to the Open APN, which is connecting the fiber sensing interrogator to the Open APN's nodes. Therefore, we must consider Open APN nodes for use with fiber sensing.

The APN nodes to which fiber sensing interrogators may connect, as shown in the fiber sensing architecture, are the APN Transceiver (APN-T) and the APN-Gateway (APN-G). Though in Type I, the interrogator is connected to an external switch that selects the fiber to be measured. This external switch is not a node of the Open APN function, it is only for fiber sensing. Therefore, this Type I external switch is not discussed here.

For the connection with APN-T, fiber sensing uses APN-T to transmit measurement data as an Open APN user or to receive control signals for remote control. The measurement data and control signals transmitted and received in these cases can be transmitted by a communication protocol defined by the Open APN, and there are no technical requirements or specifications for the fiber sensing system. There is no technical gap and no problem in connecting APN-T to the interrogator. As a result, we discuss the connection between APN-G and the interrogator in this section.

4.2. Technical gap of connection between APN-G and fiber sensing interrogator

Fiber sensing, in Type II and Type III, utilizes the switching function of APN-G to select the fibers to be measured. A fiber sensing interrogator inserts a probe light into a fiber to be measured and receives its backscattered light. This causes two optical pulses, probe light and backscattered light, to propagate simultaneously in opposite directions in the same fiber. The technical gap, and the challenge, for the connection of the APN-G and the interrogator is that APN-G has to transfer both the probe light and the backscattered light of the fiber sensor propagating backward on the same fiber.

Here is a general idea that is assumed for APN-G. Denote U_{gg}/U_{gi} (U_{gg} – optical interface between two APN-Gs. U_{gi} – optical interface between APN-G and APN-I) for the interface between APN-G or between APN-G and APN-I, respectively, and U_{gt} for the interface between APN-G and APN-T. Figure 4.1 shows an APN-G configuration with

amplification. Given the current situation of commercially available switching nodes, APN-G is expected to include optical amplifiers. Amplifiers would be inserted in Ugg/Ugi side fibers. When the switching loss to the Ugt side is large, there also would be an amplifier for the Ugt side. The amplifier in the APN-G configuration restricts the direction of light propagation to one direction. On the other hand, in many fiber sensing techniques, probe light and backscattered light travel in opposite directions in the same fiber. As a result, the interrogator should be connected to the APN-G in such a special configuration that the probe and backscattered light can propagate simultaneously in the one measured fiber while avoiding an amplifier that passes only one direction of light. This enables normal fiber sensing without interference.

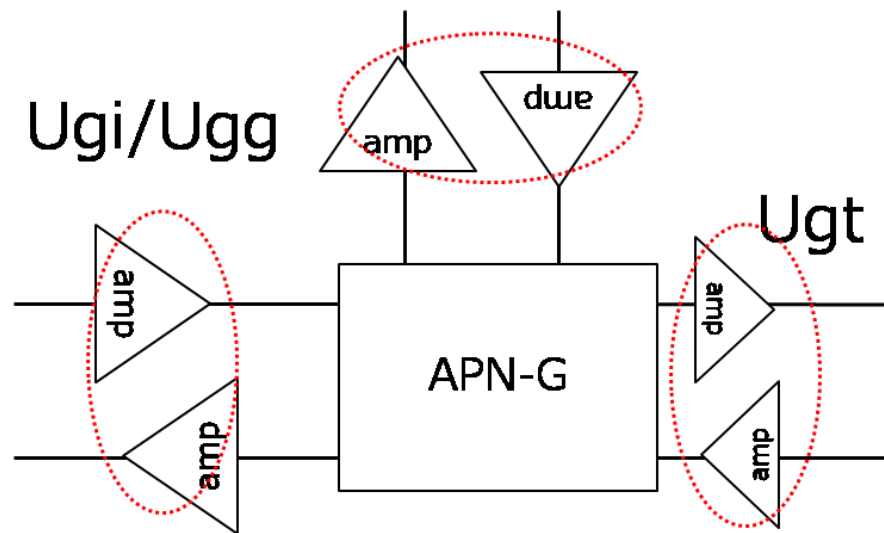

Figure 4-1 APN-G configuration with amplification

The APN-G is also the first NW node when you think of the APN-T as a communication origin. Therefore, depending on the number of users, large numbers of APN-Gs may be located in the central office. On the other hand, it is not easy to install many fiber sensing interrogators in one place because fiber sensing interrogators can be highly functional and expensive measuring instruments. Therefore, probe light from one interrogator is expected to be distributed by an external switch and inserted into many APN gateways. However, as shown in Figure 4.2, it is difficult for the probe light from the interrogator to pass through multiple APN-Gs because of the amplifier.

That is, avoiding the one-way communication of the amplifier to enable fiber sensing will be a significant technical challenge for accomplishing APN-G with fiber sensing.

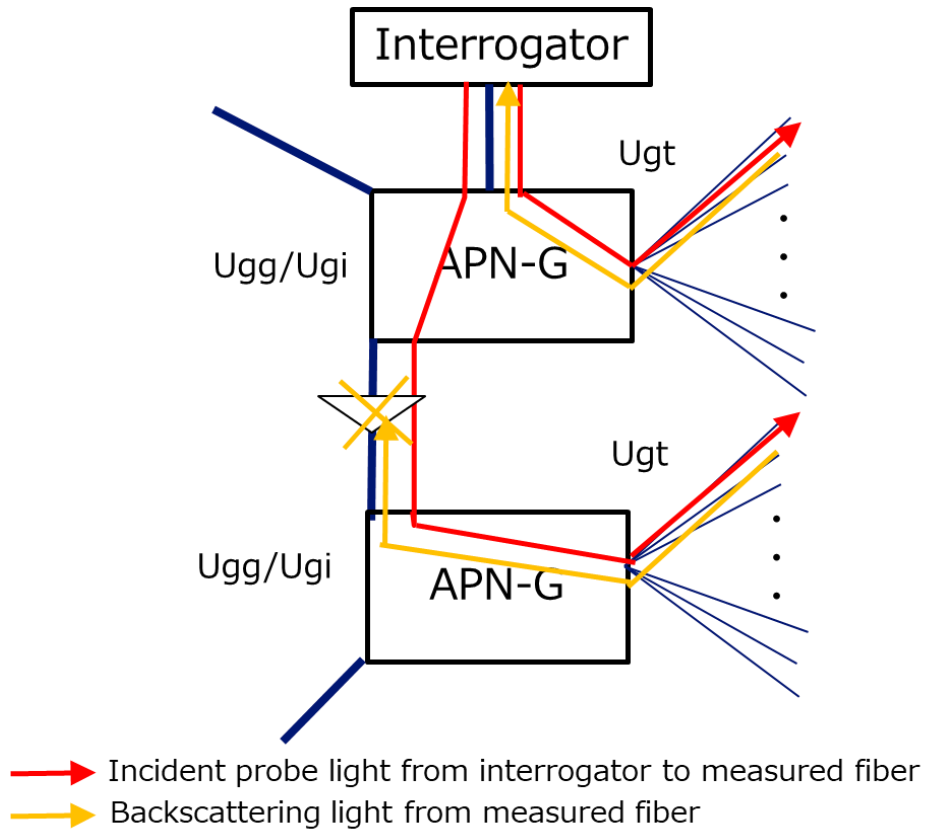

Figure 4-2 Probe light from the interrogator to pass through multiple APN-Gs

4.3. Examples of countermeasures for the technical gap of the connection between APN-G and fiber sensing interrogator

This subsection shows examples of countermeasures for the technical gap of connection between APN-G and fiber sensing interrogators. The feasibility and effectiveness of the methods described here have not been confirmed and should be carefully considered in the future. Additionally, these methods are just examples, and the connection patterns are not limited to them. There may be more suitable methods.

First, when multiple APN-Gs are used with a single interrogator, one example of a countermeasure is to use an external switch dedicated to fiber sensing in the first stage for selecting each APN-G as shown in Figure 4.3.

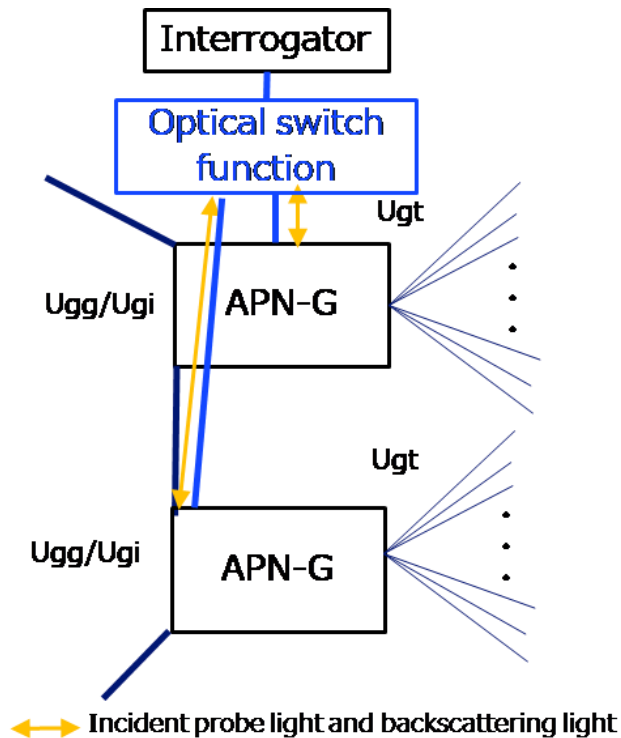

Figure 4-3 External switch dedicated to fiber sensing in the first stage for selecting each APN-G

As examples of countermeasures for avoiding amplifiers and selecting fibers to measure using APN-G, Figures 4.4, 4.5, and 4.6 show configurations using circulators. The circulator can insert/retrieve the probe light to/from the optical path with very little loss to either the fiber sensing probe light or the communication light. However, the circulators may not be common devices in telecommunication networks.

In Figure 4.4, a probe light is inserted into APN-G through the circulator (A) and injected into the fiber through the APN-G and the circulator (B). Scattering light is separated with the circulator (B), transmitted to the circulator (A), and received by the interrogator. Because of two circulators, the probe light can be inserted into the measurement fiber and the backscattered light can be extracted from the measurement fiber with a low loss. The loss of APN-G can be compensated by the amplifier. The APN-G can be utilized for the selected sensing fiber. In Figure 4.5, the paths of the probe light and scattering light are exchanged. The effect of being able to bypass the amplifier is the same. The probe light insertion port and the backscattered light output port of APN-G may be either the Ugi/Ugg side or the Ugt side.

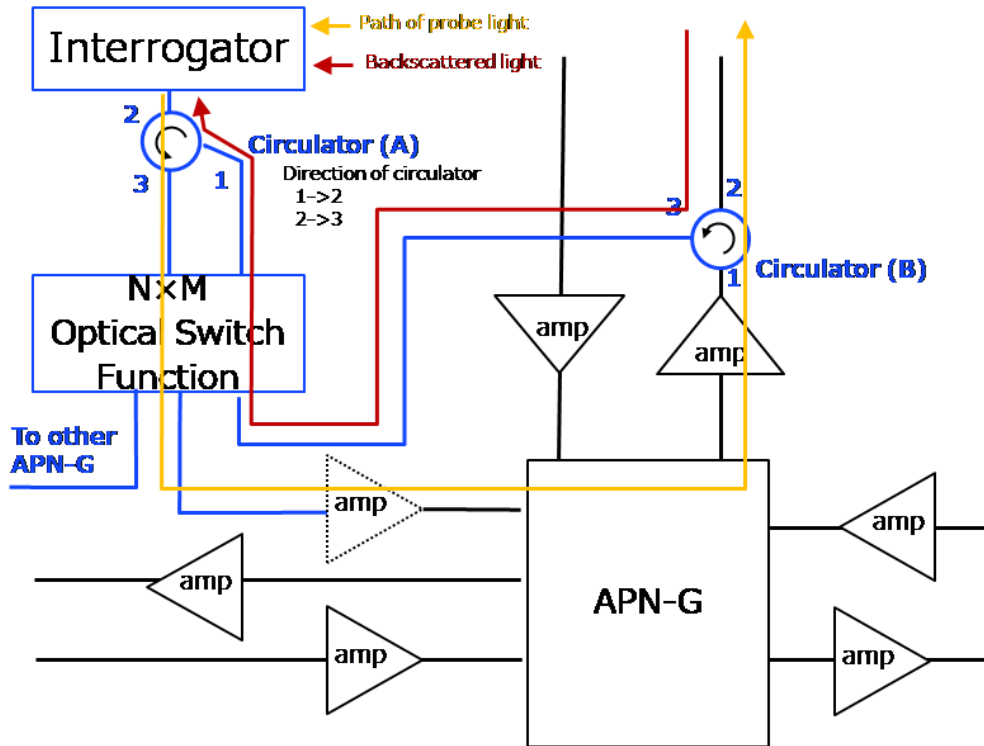

Figure 4-4 Configuration using circulator where backscattered light is inserted into APN-G through the circulator

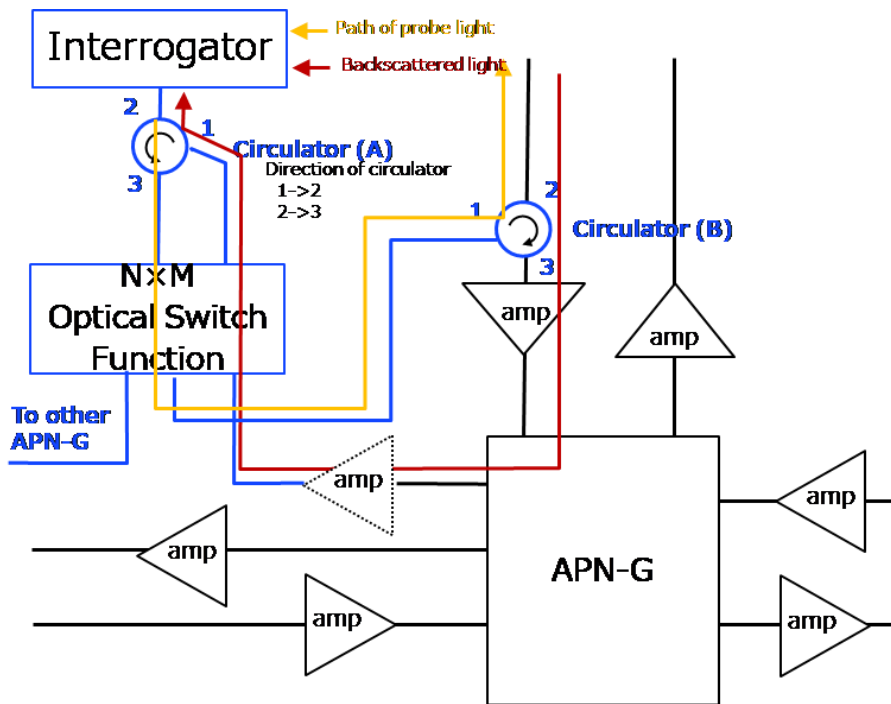

Figure 4-5 Configuration using circulator where backscattered light is inserted into APN-G through the circulator

A final countermeasure is the simple configuration with couplers shown in Figure 4.6. Although this configuration is uncomplicated, losses at the couplers are significant and they may restrict the performance of both communications and fiber sensing.

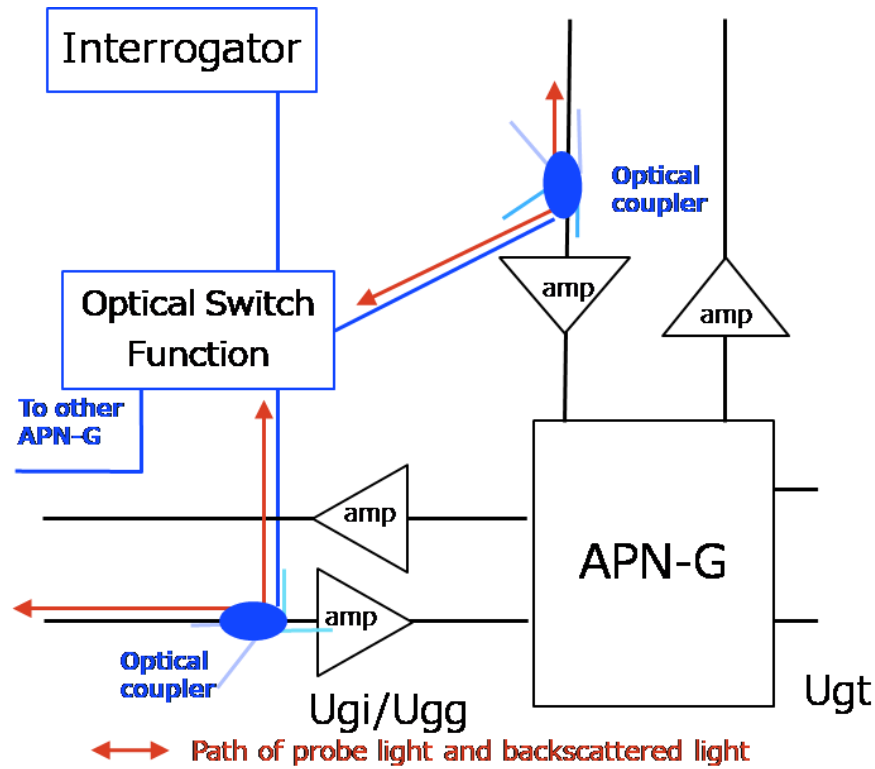

Figure 4-6 Configuration with couplers

5. Data Channel

5.1. “Remote control” and “data transmission”

Data channels are classified into remote control, which remotely controls the interrogator, and data transmission, which transmits measurement data from the interrogator to a remote location.

Control signals do not constantly consume bandwidth, so they can be transmitted with the APN-C control plane.

Depending on the use case, data transmission constantly consumes bandwidth, so using the APN-C control plane may affect the other APN control.

Therefore, a method of using the Open APN data plane for data transmission can be considered, e.g., Type D1/D2 (Bandwidth Reservation) of FlexBridge can be a viable candidate.

This Section describes data transmission using the Open APN.

5.2. Patterns of “data transmission”

In considering the data channel, it is necessary to weigh how much measurement data is transferred, how often, and where. Patterns of “Data transmission” for fiber sensing can be categorized into the following three categories.

1) Data streaming transfer (for continuous monitoring)

All measured data by the interrogator is continuously transferred to a remote location. The data channel transfer rate must exceed the measured data generation rate at the interrogator. On the other hand, the interrogator does not need buffering and processing of measured data.

2) Partial data transfer (for on-demand monitoring)

A method whereby selective data by the interrogator is transferred to the remote location, rather than all data. There is no problem even if the transfer speed of the data channel is lower than the data generation speed of the interrogator, but depending on the use case, the interrogator must have a function to buffer retained data.

3) Processed data transfer (for alert monitoring)

In this case, it is necessary to transfer not all of data, but only the result of some algorithmic process that is performed by the interrogator. Although processing functions are required on the interrogator side according to the use case, the conditions for the data channel are not significant since there is no need to transfer raw data.

5.3. Data capacity and bandwidth

The most demanding case for data transfer capacity is for data streaming transfers.

For example, a resolution of 0.1 m, a sampling rate of 16 bits, and the number of channels of 2, the interrogator generates 32 Gbps of data (refer to *1), so the data capacity and bandwidth should be greater than 32Gbps.

< Data capacity calculation >

Data rate for raw data transmission [bps] depends on measurement conditions. It could be approximately obtained by following equations.

Data rate for raw data transmission = $S_s \times 1/T_s$.

$S_s = L / R \times N_b \times N_c$.

$T_s = 2L / c_g$.

Here, S_s [bit] is the data size per single measurement. T_s [s] is measurement time per single measurement. L [m] is measurement distance, i.e., the length of the sensor fiber. R [m] is spatial sampling resolution. N_b [bit] is the number of bit per single data point (typically 16 [bit]). N_c is the number of measurement channels that depends on measurement methods. c_g [m/s] is the light speed in a fiber.

As shown below, the Data rate (D_r) can be simplified as canceling the fiber length L [m].

$D_r = S_s \times 1/T_s = (N_b \times N_c \times C_g) / 2R$.

Substitute following sample parameters to the formula, the Data Rate is approximately 32Gbps.

< Sample parameters >

$$N_b = 16 \text{ [bits]}$$

$$N_c = 2 \text{ [channels]}$$

$$C_g = 2 \times 10^8 \text{ [m/s]}$$

$$R = 0.1 \text{ [m]}$$

<Formula>

$$D_r = (16 \times 2 \times 2 \times 10^8) / (2 \times 0.1) = 32 \text{ [Gbps]}$$

5.4. Data processing

As described in 5.3, if the data capacity and bandwidth required for raw data streaming transfer is satisfied, processing and buffering on the interrogator is unnecessary.

In cases of “Partial data transfer” and “Processed data transfer”, the processing and buffering capabilities are required on the interrogator. Since it depends on the use case, requirements for data processing and buffering are not described here.

5.5. Latency

This Section does not describe latency. Depending on use cases, the location of the data processing unit (near the interrogator or remote site), the amount of data, the cycle of measurement, etc. needs to be collected if the data processing unit differs.

6. System Control

6.1. Control mechanism

This section describes the system control mechanism for fiber sensing within the Open APN, and the architecture around the controller to perform fiber sensing with the Open APN.

When fiber sensing is performed with the Open APN, it is necessary to acquire information about the telecommunications fiber and the facilities of the Open APN. It is also important to control the optical path switches of the Open APN in order to establish the sensing path from the interrogator. These controls of the Open APN are performed by the Open APN controller. It is also necessary to control the interrogator and translation of measurement data. This control is performed by the fiber sensing controller (FS controller).

Optical fiber sensing serves two purposes with the Open APN. One is sensing to obtain information about the environment and external events occurring around the optical fiber cable. The other is sensing for telemetry to detect anomalies in optical fiber cables, e.g., losses, reflections, and faults. The fiber sensing method used for these two use cases is a distributed measurement generated by gathering and analyzing backscattered light.

However, the means of measurement is different for these two cases. The measurer of telemetry is the telecommunication carrier, and the measurer of environmental sensing are various sensing service providers. We need to consider two different systems control mechanisms due to the difference between measurers.

The Open APN controller can be directly controlled if the telecommunication carrier performs fiber sensing for telemetry because the Open APN controller belongs to the telecommunication carrier. On the other hand, if sensing service providers beyond the telecommunications carrier wish to perform environmental and event sensing, they must send a request to the Open APN controller from the FS controller based on the manner of the interaction with APN controller. Thus, the control mechanism is different depending on the purpose of the sensing.

The two types of system control mechanisms based on the difference are described below.

Here's a note: The control mechanisms described below are examples of the mechanism to achieve fiber sensing with Open APN. Other mechanisms are fine as long as the fiber sensing can be performed with Open APN.

As shown in Figure 6.1, in the case of telemetry performed by a telecommunication carrier, the Open APN controller will first give the order to the FS controller that includes the selected fiber and suitable fiber information. The FS controller then sends a control signal to the interrogator. After measurement, the interrogator transfers sensing data to the site for data analysis and storage. Finally, the Open APN controller can refer to analyzed results for telemetry.

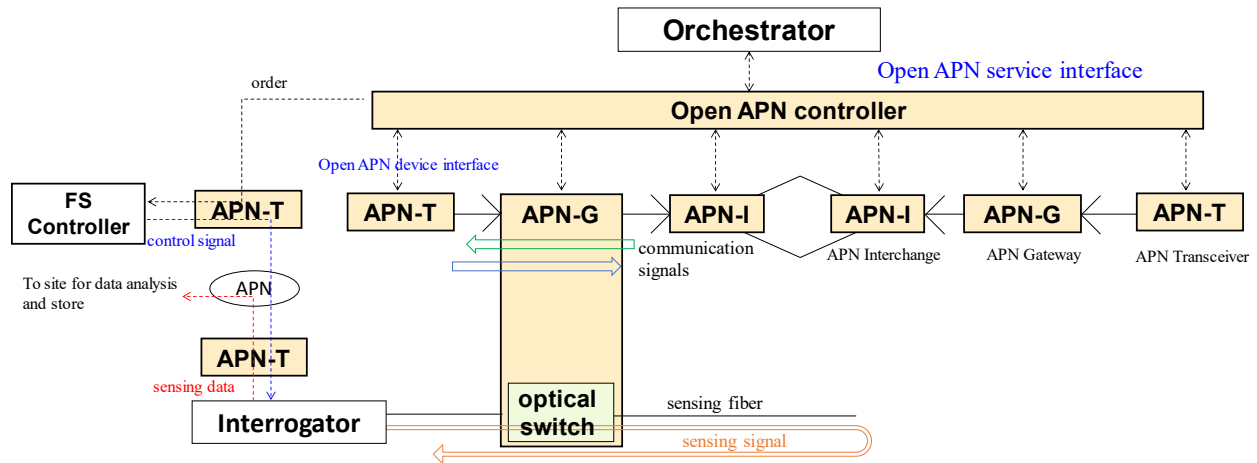

Figure 6-1 System control for telemetry

As shown in Figure 6.2, for environmental sensing, at first, FS controller prepared by the sensing service provider sends a request to the Open APN controller. Then, based on the request from the FS controller, the APN controller sends a response to the FS controller. Based on that response, the FS controller sends a control signal to the interrogator. After measurement, sensing data will be transported from interrogator to the site of the sensing service provider for data analysis and storage. This procedure is an example of the system's control.

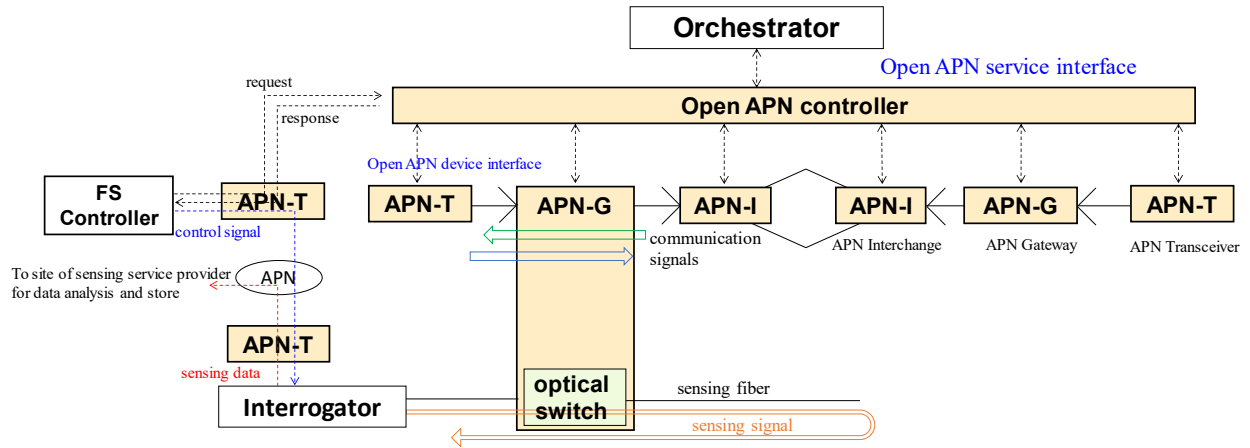

Figure 6-2 System control for environmental sensing

Definition of this architecture common technical specific terms:

- Environmental sensing: sensing for obtaining information about the environments and external events occurring around the optical fiber cable with the measurement of the temperature, strain, etc., of the fiber.
- Telemetry: sensing to detect anomalies in optical fiber cables, e.g., losses, reflections, and faults
- Control signal: order to perform sensing to the interrogator based on the order and response from the Open APN controller. Interrogator-related parameters, such as pulse width, wavelength and period, etc., are also included.
- Sensing signal: the probe light injected into a fiber and the back-scattered light.
- Sensing data: the data measured by the interrogator.

7. Conclusion

Fiber-optic sensing is a unique feature for the IOWN Global Forum's Open APN. Beside the conventional communication function, fiber-optic networks can now provide sensing as an overlay benefit. In concept the entire fiber-optic network can function as a large sensor, realizing the new paradigm of Network-as-a-Sensor (NaaSr). This added functionality of the fiber-optic network promises to not only improve the reliability of networks, but also enables new applications and services. These benefits and some use-case examples were described in FSOA 1.0 document.

Adding sensing functions to the existing fiber-optic communication network cannot be achieved by simply combining the communication network and the optical sensors, since these two types of systems have different requirements and configurations in various aspects. In other words, there are technical gaps between them. It is therefore necessary to analyze these gaps and propose solutions to bridge them so that fiber-optic sensing features can be seamlessly added to the Open APN.

Comparing the communication and sensing functions, the Open APN's main role is still data communication and networking, with sensing as an attractive low-cost addition. The need to bridge the gap comes mainly from the sensing side.

In this document, key technical gap areas are discussed, including the optical requirements of the probe laser (such as the peak power and total power, the laser linewidth, the bandwidth, and the wavelength tunability), the optical fibers, cables, and design considerations, the integration of fiber sensing subsystems to APN Gateway, the data channel requirement, and the system controls requirements. Some evaluation methods are raised. Some countermeasures to bridge these gaps are discussed, with practical examples proposed. These will provide potential solutions to add fiber sensing to communication networks. Some of these evaluation methods and solutions are currently being studied in IOWN GF's various Proof-of-Concept (PoC) experiments.

Among the 4 types of fiber sensing architectures described in FSOA 1.0, there are different areas of technical gap. Type I has the least consequential gap and can be integrated with Open APN most easily. On the other hand, Type III has significant technical challenges to overcome and will require considerable (but plausible) amounts of effort to achieve. Therefore, it is expected that Type I will be adopted in the Open APN first, followed by Type II-1 and Type II-2, with Type III will be adopted in later stages.

It should be noted that the recommendations proposed in this document are not the only solutions, best solutions, or preferred solutions. As OAF Task Force members continue to study these issues together and work with other IOWN members through cross-task

force collaboration, more solutions may be developed and implemented in IOWN GF's Open APN.

In conclusion, by studying the technical gaps and potential solutions in this document, we are one step further toward actualizing optical sensing as a new function in IOWN GF's Open APN. It is hoped that more stakeholders are encouraged to participate in this study and to provide diverse and specific solutions for fiber sensing over Open APN.

References

<p>[FSOA 1.0]</p>	<p>IOWN Global Forum, “Fiber sensing for Open APN” release-1,” 2022. https://iowngf.org/wp-content/uploads/formidable/21/IOWN-GF-RD-FS-for-Open-APN-1.0-1.pdf</p>
-----------------------	--

History

Revision	Release Date	Summary of Changes
1	February 2023	Initial Release