



**IOWN**  
GLOBAL FORUM™

# PoC Reference of Mobile Fronthaul over APN

---

Classification: APPROVED REFERENCE DOCUMENT

Confidentiality: PUBLIC

Version 2

August 2024

[MFH/APN PoC Reference]

## Legal

THIS DOCUMENT HAS BEEN DESIGNATED BY THE INNOVATIVE OPTICAL AND WIRELESS NETWORK GLOBAL FORUM, INC. ("IOWN GLOBAL FORUM") AS AN APPROVED REFERENCE DOCUMENT AS SUCH TERM IS USED IN THE IOWN GLOBAL FORUM INTELLECTUAL PROPERTY RIGHTS POLICY (THIS "REFERENCE DOCUMENT").

THIS REFERENCE DOCUMENT IS PROVIDED "AS IS" WITH NO WARRANTIES WHATSOEVER, WHETHER EXPRESS, IMPLIED, STATUTORY, OR OTHERWISE, INCLUDING WITHOUT LIMITATION ANY WARRANTY OF MERCHANTABILITY, NONINFRINGEMENT OF THIRD PARTY RIGHTS, TITLE, VALIDITY OF RIGHTS IN, FITNESS FOR ANY PARTICULAR PURPOSE, OR ANY WARRANTY OTHERWISE ARISING OUT OF ANY PROPOSAL, REFERENCE DOCUMENT, SAMPLE, OR LAW. WITHOUT LIMITATION, IOWN GLOBAL FORUM DISCLAIMS ALL LIABILITY, INCLUDING WITHOUT LIMITATION LIABILITY FOR INFRINGEMENT OF ANY PROPRIETARY RIGHTS AND PRODUCTS LIABILITY, RELATING TO USE OF THE INFORMATION IN THIS REFERENCE DOCUMENT AND TO ANY USE OF THIS REFERENCE DOCUMENT IN CONNECTION WITH THE DEVELOPMENT OF ANY PRODUCT OR SERVICE, AND IOWN GLOBAL FORUM DISCLAIMS ALL LIABILITY FOR COST OF PROCUREMENT OF SUBSTITUTE GOODS OR SERVICES, LOST PROFITS, LOSS OF USE, LOSS OF DATA OR ANY INCIDENTAL, CONSEQUENTIAL, DIRECT, INDIRECT, PUNITIVE, EXEMPLARY, OR SPECIAL DAMAGES, WHETHER UNDER CONTRACT, TORT, WARRANTY OR OTHERWISE, ARISING IN ANY WAY OUT OF USE OR RELIANCE UPON THIS REFERENCE DOCUMENT OR ANY INFORMATION HEREIN.

EXCEPT AS EXPRESSLY SET FORTH IN THE PARAGRAPH DIRECTLY BELOW, NO LICENSE IS GRANTED HEREIN, EXPRESS OR IMPLIED, BY ESTOPPEL OR OTHERWISE, TO ANY INTELLECTUAL PROPERTY RIGHTS OF THE IOWN GLOBAL FORUM, ANY IOWN GLOBAL FORUM MEMBER OR ANY AFFILIATE OF ANY IOWN GLOBAL FORUM MEMBER. EXCEPT AS EXPRESSLY SET FORTH IN THE PARAGRAPH DIRECTLY BELOW, ALL RIGHTS IN THIS REFERENCE DOCUMENT ARE RESERVED.

A limited, non-exclusive, non-transferable, non-assignable, non-sublicensable license is hereby granted by IOWN Global Forum to you to copy, reproduce, and use this Reference Document for internal use only. You must retain this page and all proprietary rights notices in all copies you make of this Reference Document under this license grant.

THIS DOCUMENT IS AN APPROVED REFERENCE DOCUMENT AND IS SUBJECT TO THE REFERENCE DOCUMENT LICENSING COMMITMENTS OF THE MEMBERS OF THE IOWN GLOBAL FORUM PURSUANT TO THE IOWN GLOBAL FORUM INTELLECTUAL PROPERTY RIGHTS POLICY. A COPY OF THE IOWN GLOBAL FORUM INTELLECTUAL PROPERTY RIGHTS POLICY CAN BE OBTAINED BY COMPLETING THE FORM AT: [www.iowngf.org/join-forum](http://www.iowngf.org/join-forum). USE OF THIS REFERENCE DOCUMENT IS SUBJECT TO THE LIMITED INTERNAL-USE ONLY LICENSE GRANTED ABOVE. IF YOU WOULD LIKE TO REQUEST A COPYRIGHT LICENSE THAT IS DIFFERENT FROM THE ONE GRANTED ABOVE (SUCH AS, BUT NOT LIMITED TO, A LICENSE TO TRANSLATE THIS REFERENCE DOCUMENT INTO ANOTHER LANGUAGE), PLEASE CONTACT US BY COMPLETING THE FORM AT: <https://iowngf.org/contact-us/>

Copyright © 2024 Innovative Optical Wireless Network Global Forum, Inc. All rights reserved. Except for the limited internal-use only license set forth above, copying or other forms of reproduction and/or distribution of this Reference Document are strictly prohibited.

The IOWN GLOBAL FORUM mark and IOWN GLOBAL FORUM & Design logo are trademarks of Innovative Optical and Wireless Network Global Forum, Inc. in the United States and other countries. Unauthorized use is strictly prohibited. IOWN is a registered and unregistered trademark of Nippon Telegraph and Telephone Corporation in the United States, Japan, and other countries. Other names and brands appearing in this document may be claimed as the property of others.

## Contents

<b>1. Scope</b> .....	<b>6</b>
<b>2. Purpose, Objectives, and Step</b> .....	<b>7</b>
2.1. Purpose .....	7
2.2. Objectives.....	8
2.3. Step .....	9
2.3.1. Step 1) Evaluation of feasibility of Mobile Fronthaul over APN .....	10
2.3.2. Step 2) Evaluation of feasibility and energy efficiency with Elastic Load Balancing....	10
2.3.2.1. Step 2.1- Evaluation points: Feasibility In realizing Elastic Load Balancing, controlling the combined RAN and optical technologies is necessary to ensure minimal service impact to the end users. We need to clarify the following points for each device of RAN and APN: .....	11
2.3.2.2. Step 2.2- Evaluation points: Energy efficiency This step is to examine the power consumption difference between the present mobile fronthaul configuration and the fronthaul configuration by incorporating Elastic Load Balancing functionality. ....	11
<b>3. Reference Cases</b> .....	<b>12</b>
3.1. Basic scenario .....	12
3.2. Step 1) Evaluation of feasibility of Mobile Fronthaul over APN scenario .....	13
3.2.1. End-to-end DWDM model model[1] .....	13
3.2.2. With a Flexible Bridge model .....	14
3.2.3. Point-to-Multipoint model .....	14
3.3. Step 2) Evaluation of feasibility and energy efficiency with Elastic Load Balancing scenario ..	15
<b>4. Technical Requirements</b> .....	<b>17</b>
4.1. Applicable to entire PoC scenarios. ....	17
4.1.1. Mobile X-haul [2] .....	17
4.1.2. Interfaces [3] .....	17
4.2. Applicable to partial PoC scenarios. ....	18
4.2.1. Transmission characteristics of optical components .....	18
<b>5. Key features</b> .....	<b>19</b>
5.1. Dynamic Path Switching for Elastic Load Balancing.....	19
5.1.1. Optical path switching .....	19
5.1.1.1. PtP topology .....	19
5.1.1.2. PtMP topology .....	20

5.1.2. Packet switching .....	20
5.1.2.1. PtP topology .....	20
5.1.2.2. PtMP topology .....	21
5.2. Dynamic configuration change of NFVI .....	22
<b>6. Key Benchmarks .....</b>	<b>23</b>
6.1. Step 1) Evaluation of feasibility of Mobile Fronthaul over APN scenario .....	23
6.1.1. Feasibility based on IMN document .....	23
6.2. Step 2) Evaluation of feasibility and energy efficiency with Elastic Load Balancing scenario ..	24
6.2.1. Step 2-1 Feasibility .....	24
6.2.2. Step 2-2 Energy efficiency .....	25
<b>Conclusions .....</b>	<b>28</b>
<b>Reference .....</b>	<b>29</b>
<b>History .....</b>	<b>30</b>
<b>Appendix I: Definition of Benchmark-First PoC.....</b>	<b>31</b>
1. Reference cases .....	31
2. Key features .....	32
3. Other .....	32
<b>Appendix II: Switching method that minimizes service impact .....</b>	<b>33</b>
<b>Appendix III: Single-fiber bidirectional access architecture .....</b>	<b>34</b>
<b>Appendix IV: Packet-optical for Load Balancing and RAN Sharing Model.....</b>	<b>35</b>
<b>Appendix V: Definition of Traffic Model and Power and Energy Consumption Measurement .....</b>	<b>38</b>

## List of Figures

Figure 1 RIM-First process vs Benchmark-First process.....	6
Figure 2. Hourly variation of area population (Urban area: Tokyo, Rural area: Tottori)※.....	9
Figure 3 Path Switching Between RU and DU in the MFH by APN.....	9
Figure 4 The step of this PoC .....	10
Figure 5. Basic Deployment scenario .....	12
Figure 6 Deployment scenario for step 1 (Minimum configuration) .....	14
Figure 7 Deployment scenario for step 1 (Minimum configuration) .....	14
Figure 8 Deployment with PtMP topology for step 1.....	14
Figure 9 Deployment scenario for step 2 .....	15
Figure 10 Deployment scenario for step 2 .....	16
Figure 11 PtMP topology of the deployment scenario in Step 2.....	16
Figure 12 Synchronization distribution with TDM PON technology .....	16

Figure 13 Optical switching-based method .....	20
Figure 14 Optical switching-based method (PtMP topology) .....	20
Figure 15 Packet switching-based method .....	21
Figure 16 Packet switching-based method (PtMP topology) .....	21
Figure 17 Reference cases .....	31
Figure 18 a switching method that minimizes service impact .....	33
Figure 19 Single-fiber bidirectional access architecture .....	34
Figure 20 Downlink and uplink fiber paths for mobile fronthaul .....	34
Figure 21 Multi-operator scenario in the extended demo .....	35

# 1. Scope

This document is intended to define Reference Cases / Technical Requirements / Key features / Key benchmarks for effect verification of applying an APN (which is defined in [3]) to Fronthaul (FH) / Midhaul (MH) / Backhaul (BH) and use cases as Elastic Load Balancing.

The intention of this Proof of Concept (PoC) is to demonstrate to mobile network operators the benefits and viability of Open APN as a fronthaul solution and offers a reference architecture of mobile fronthaul over APN as a service.

The RIM-First process defines the Reference Implementation Model in the PoC Reference document before the Member’s PoC implementation. On the other hand, the Benchmark-First process establishes the game rules under which members explore the best technology and implementation approaches, covering reference cases, mandatory features, and key benchmarks. If a RIM for a member’s PoC has not been defined yet, the member could select the Benchmark-First process based on the game rules in Appendix I. Note that the Benchmark-First PoC method is the alternative method to following the reference case in this version of PoC reference document. Members working on Benchmark-First PoC capable of adapting a functional architecture (Open APN or DCI) must report their proposed reference model and implementation details, along with a report of PoC results showcasing how these results achieved the benchmark parameters. The successful Benchmark-first PoC results can then be extracted to develop a RIM.

When proceeding with the RIM-First process, please refer to the main body of this document. When proceeding with the Benchmark-First process, please refer to Appendix 1, as well as Chapters 1, 2, 4, and 6 of the main body of this document. For the reference model descriptions in Chapters 3 and 5, please consult them when creating the PoC Report.

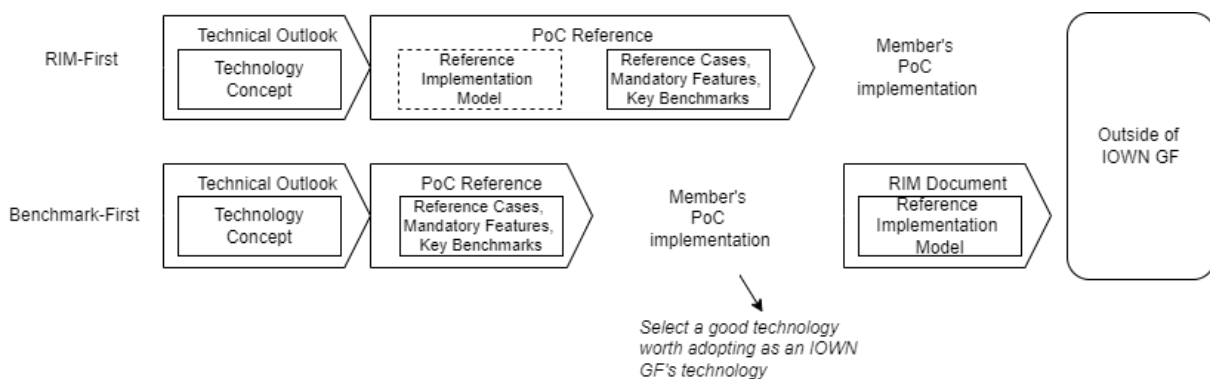

Figure 1 RIM-First process vs Benchmark-First process

## 2. Purpose, Objectives, and Step

### 2.1. Purpose

The portion of emerging disaggregated radio access networks for 5G (and beyond) that connect baseband processing units (BBUs) with remote radio heads (RRHs), known as “fronthaul,” has high capacity, high availability, and stringent latency requirements. The IOWN Global Forum has defined and calculated these stringent fronthaul requirements, particularly for the use cases envisioned by the IOWN GF [1].

Mobile fronthaul over APN is believed to be a viable solution to meet such requirements. Various technologies and architectures are being considered as fronthaul solutions, among which Open APN has potential to be widely recognized as a leading fronthaul solution as it demonstrates many benefits better than other schemes.

A lower layer split (LLS) option of RAN (e.g., Option 7 in 3GPP TR 38.801[4]), which is gaining popularity with multiple developers, promotes an architecture that allows more functions to be centralized. However, to make RAN LLS more compelling, the cost and availability of high-capacity fiber optical fronthaul links must be considered as more stringent requirements of massive bandwidth and tight latency come with LLS (Section 2.1 of [2]).

The recognition of Mobile Fronthaul (MFH) over APN as a viable and promising solution is expected to encourage mobile network operators worldwide to accept MFH over APN and further promote IOWN GF-related technologies.

We expect that the APN reduces the energy consumption of mobile fronthaul because an APN can, for example, reduce electric to optical conversion and vice versa, resulting in less operational cost.

Besides energy efficiency gain, we expect operators to benefit greatly from an APN’s path reconfigurability. For example, operators will be able to dynamically change the RU (which is Radio Unit comprising the radio wave emitting hardware) -DU (which is Distributed Unit containing most of the baseband functionality) connections in accordance with the variation of actual traffic, e.g., from daytime to nighttime. In the remainder of this document, we refer to this use case as Elastic Load Balancing (ELB). In addition, operators can make their DU platform more resilient by re-configuring RUs in case the primary path fails. This reconfigurability provides equally a higher availability to the overall mobile network in the event of failures.

In addition, a single-fiber bidirectional access architecture (using an optical duplexer or other passive optical components) can also be considered in order to save fiber resources and OPEX.

The Elastic Load Balancing feature demonstrated in the PoC will allow for greater flexibility and efficient resource utilization in the MFH network. This is expected to improve the availability and power efficiency of the RAN system compared to conventional MFH. In terms of power efficiency, it is expected that this will improve the power efficiency of the RAN system, as

unused DCI resources (vDU(s) which is virtualized DU) are shut down or go into low power mode and thus have no associated power consumption.

This study examines the possibilities of IOWN APN through a Proof of Concept (PoC) for Mobile Fronthaul over All-Photonic Network. We not only analyze the technological feasibility but also conduct a thorough assessment of the Total Cost of Ownership (TCO) and Return on Investment (ROI). Understanding these metrics will be crucial for stakeholders to assess the financial and business implications of adopting cutting-edge photonic network technologies.

## 2.2. Objectives

The goal of this PoC is to showcase MFH over APN, demonstrating Elastic Load Balancing and its significance to mobile network operators. The primary aim is to diminish power consumption by centralizing mobile processing and deactivating idle resources.

Figure 2 shows the hourly number of connected mobile User Equipment (UE) to the mobile network in an urban and rural and illustrates the steep differences in the number of connected UEs during day and during the night. The difference between the observed day and night is at least 10x, but it is typically higher for an urban area, while for the rural areas, it is 5x between day and night. As the number of connected UEs in a particular area varies, so does the required amount of mobile network necessary resources proportionally. When dynamic allocation of computing resources of DU is not possible, it is necessary to provision statically peak-rated resources, which is very inefficient from a cost point of view but equally from an energy consumption point of view. IOWN GF Elastic Load Balancing solves this challenge.

Elastic Load Balancing is a mechanism that flexibly allocates the DUs (vDUs) implemented on virtual machines, depending on the load on the host, minimizing the number of processing units.

There are essentially two sides in a mobile fronthaul architecture. One side is where the RUs are located and the other side is where the DU are located. There are at least two vDUs at the DU site, and the network operates with a number of provisioned vDUs based on the total number of UEs allocated to the RU and the traffic volume between the RU and DU. During peak times, a large number of vDU is needed, and that number decreases during off-peak times as the number of UEs under the RU equally decreases.

Figure 3Figure 2 illustrates the switching between the day and night (or peak and off-peak) configurations. Today, it is necessary to manually reconfigure the association between the vDU and RU in order to transition between peak and off-peak periods. The reconfiguration consists of mobile control plane and network reconfiguration. Elastic Load Balancing provides a pragmatic approach to reduce the complexity of the reconfiguration. The vDUs no longer used during off-peak times after the reconfiguration are moved into low-power hibernation mode or shut down. See Section 5 for methods to implement Elastic Load Balancing. The APN realization model over MFH can be End-to-end DWDM, Flexible Bridge, and Point-to-Multipoint.

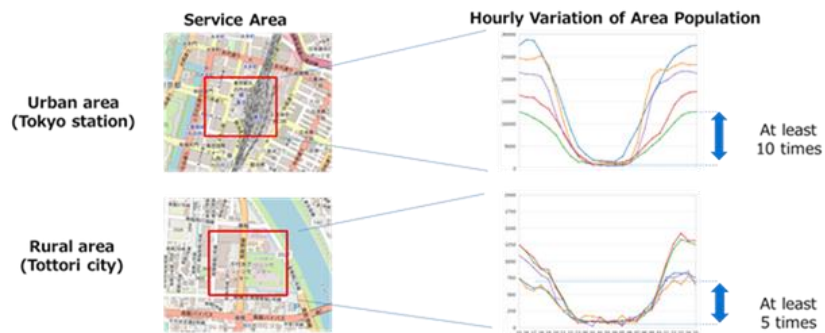

Figure 2. Hourly variation of area population (Urban area: Tokyo, Rural area: Tottori) ※

※The data is provided by NTT docomo (see <https://mobaku.jp/about/>).

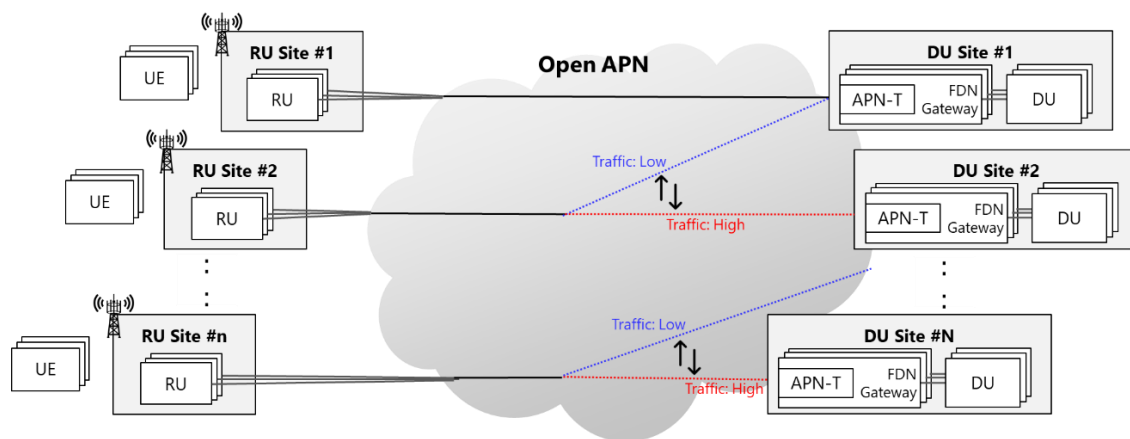

Figure 3 Path Switching Between RU and DU in the MFH by APN

### 2.3. Step

This PoC evaluates the power efficiency of Elastic Load Balancing and the impact on E2E traffic due in the event that the RU-DU is reconfigured from a peak to an off-peak topology, and vice versa; as shown in the following figure, Figure 4, which is described in the 4.2.3 section of the IMN document [2]. The virtual network inside the physical compute node will not be evaluated.

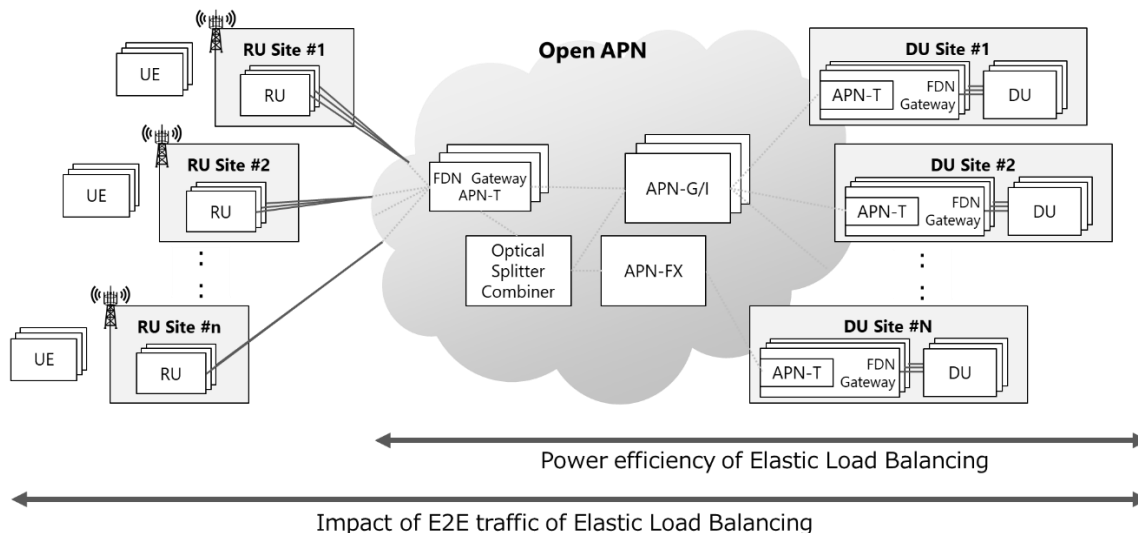

Figure 4 The step of this PoC

There are two concepts to be evaluated.

- (1) The viability of Mobile Fronthaul over APN, as outlined in Section 4.2.3 of the IMN document [2].
- (2) Elastic load balancing, as explained in Section 2.2, with a focus on enhancing energy efficiency.

Energy savings through Elastic Load Balancing are also considered a use case in the IOWN GF Energy Efficiency Program.

This PoC will validate these two concepts in two steps:

### 2.3.1. Step 1) Evaluation of feasibility of Mobile Fronthaul over APN

Evaluation points: Assessment of the viability of implementing Mobile Fronthaul over APN. This step is to clarify whether the technical specifications of MFH [5] are satisfied by the inclusion of the APN device and whether there are any other technical issues with the proposed model.

- O-RAN specification (O-RAN Fronthaul Interoperability Test Specification (IOT)) [5]
- Technical requirement from IMN document [2]

### 2.3.2. Step 2) Evaluation of feasibility and energy efficiency with Elastic Load Balancing

First, the feasibility of the Elastic Load Balancing use case in the current RAN using APN technologies needs to be determined. For example, it is necessary to evaluate not only the time required to switch RAN equipment and APN equipment, but also the impact and extent of the switch on communication services. After determining the feasibility, we will discuss the effects of energy efficiency.

### **2.3.2.1. Step 2.1- Evaluation points: Feasibility**

In realizing Elastic Load Balancing, controlling the combined RAN and optical technologies is necessary to ensure minimal service impact to the end users. We need to clarify the following points for each device of RAN and APN:

- What kind of control is needed and in what order
- What kind of service impact (content and time) can be expected
- Whether there are any other technical issues or not.

### **2.3.2.2. Step 2.2- Evaluation points: Energy efficiency**

This step is to examine the power consumption difference between the present mobile fronthaul configuration and the fronthaul configuration by incorporating Elastic Load Balancing functionality.

## 3. Reference Cases

### 3.1. Basic scenario

As illustrated in Figure 5, this PoC considers the distribution and connectivity of RUs and vDUs over different distances. In this case, L1 is the distance between the RU site where the RU is installed and the APN site where the APN device is installed, and L2 is the distance between the APN site and the DU site where the DU is installed. To increase the effectiveness of fiber usage in the case of the decentralization C-RAN architectures, DWDM is used as the multiplexing technology to make the distance between RU and DU ( $L1+L2$ ) as long as possible.

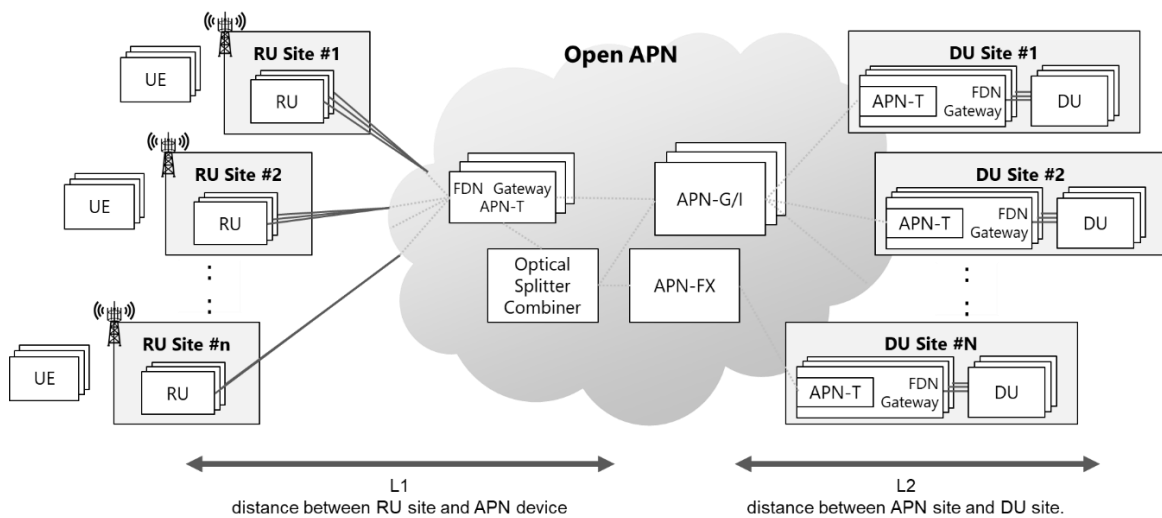

Figure 5. Basic Deployment scenario

In this PoC, the location of each APN device is not specified. As the current deployment of the base stations and the interconnectivity has various different realizations, IOWN GF allows for various alternative choices. Therefore, it is expected that the deployment arrangement of APN equipment will also differ.

Therefore, each APN device may be installed at an RU or a DU site or at another intermediate aggregation site before consolidated by the APN.

In a Point-to-Multipoint (PtMP) topology the Extra Network FDN Gateways at the RU side (acting as FlexBridges) are the PtMP Leaf nodes each with a Leaf PtMP Transceiver (“Leaf TRx”), and the Extra Network FDN Gateway at the DU side (acting as FlexBridge) is the PtMP Hub node with a Hub PtMP Transceiver (“Hub TRx”). The optical-path bandwidth is shared among the multiple Leaf TRxs with a sub-lambda multiplexing technique (Time Division Multiplexing or Sub-Carrier Multiplexing).

Depending on the use case or operator preference, there can either be one Leaf equipment for each RU, or multiple RUs can be multiplexed in a single Leaf equipment. Additionally, the Hub node can be co-located with the DU in the same site (as shown in the figure), or at a different location if the total propagation latency permits it. Optional extra network nodes can be used between the Hub node and the DUs (e.g., a QoS-aware switch) if needed.

The use of APN-G depends on the PtMP technology. Referring to the IOWN Open All-Photonic Network (APN) Functional Architecture document [3], the XR Optics which uses sub-carrier multiplexing technology is described in Appendix I.1.1 as a PtMP wavelength path with APN-G, and the TDM PON technology is described in Appendix I.1.4 as a PtMP fiber path without APN-G.

Additional characteristics associated with the different scenarios:

- The assumed mobile functional layer split architecture is: Option7.2
- The traffic is assumed to be eMBB, though it is not restricted to this type only.
- The interface of the interconnections: depends on the RU/DU used in the PoC environment (10G/25G/50G)
- Distance between RU and DU (L1+L2) :As close to 30km as possible. [1]
- All RU, DU, and APN devices will be actual physical equipment.
- If possible, the configuration of APN-I is preferred, but configurations without APN-I are also acceptable.

### 3.2. Step 1) Evaluation of feasibility of Mobile Fronthaul over APN scenario

A minimal network configuration is described here for the performance of a feasibility study. Assuming multiple RU sites at a single DU site and multiplexing them into a single fiber, at least two RU sites are required.

- Although the DU interface needs to comply with O-RAN, it does not necessarily need to be a virtualized RAN.
- Minimum number of devices
  - RU site : 2
  - RU per RU site : 1
  - DU site : 2
  - DU per DU site : 1
  - RU site per DU site : 1
- Traffic volume from UE : fixed
- Time synchronization scenario : LLS-C1/C2/C3[6]

#### 3.2.1. End-to-end DWDM model model[1]

In this model, an APN provides a wavelength path as a transport for FH/MH/BH and does not terminate the FH/MH/BH protocol.

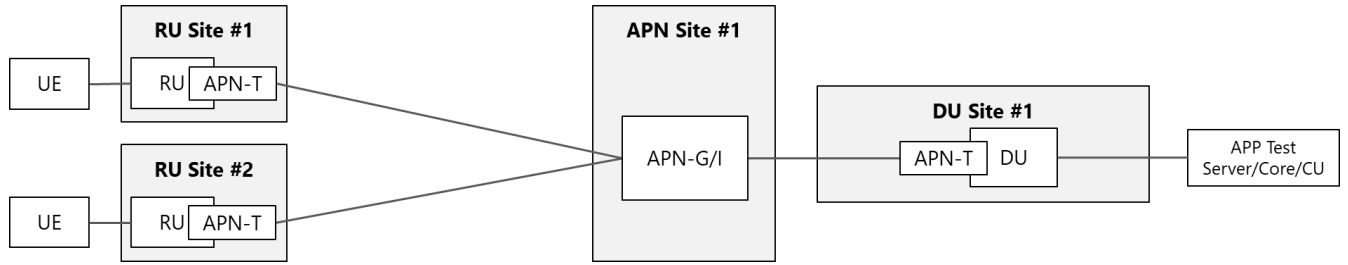

Figure 6 Deployment scenario for step 1 (Minimum configuration)

### 3.2.2. With a Flexible Bridge model

This model utilizes bridge functions such as the Flexible Bridge Service, as shown in Annex A of [3].

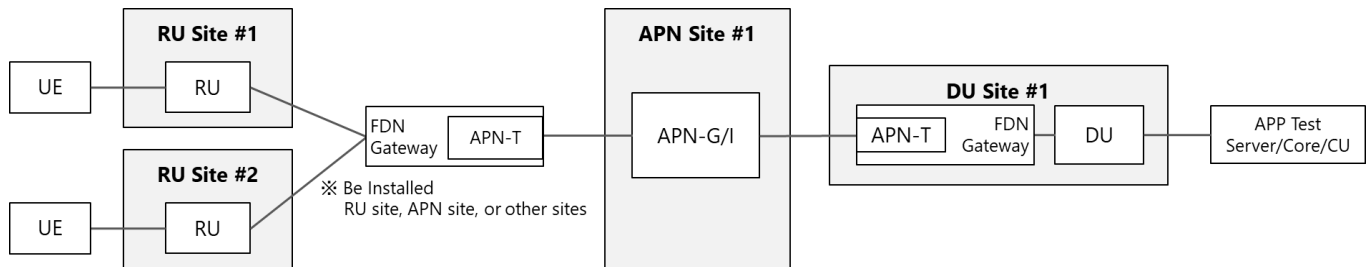

Figure 7 Deployment scenario for step 1 (Minimum configuration)

### 3.2.3. Point-to-Multipoint model

This model uses a point-to-multipoint path service that APN provides as described in 2.1 of [3]. The technology used to realize point-to-multipoint communication may include Time Domain Multiplexing or Subcarrier Multiplexing, as described in Annex F.1. of [3]. The use of APN-G depends on the Point-to-Multipoint technology.

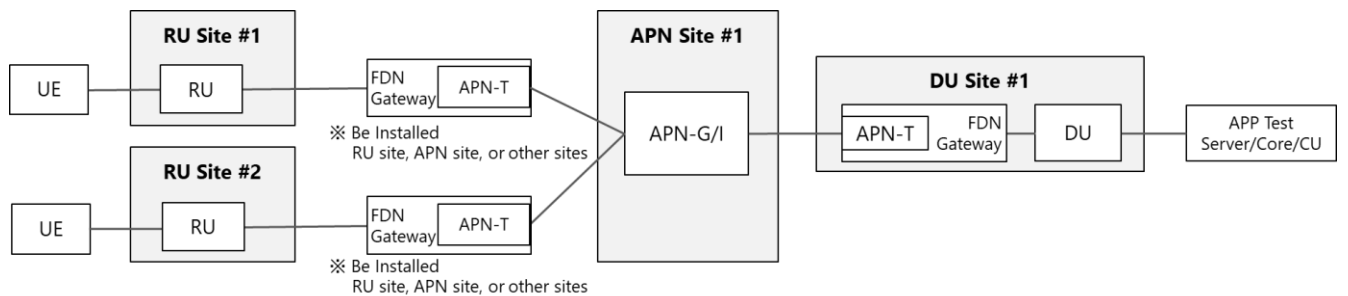

Figure 8 Deployment with PtMP topology for step 1

The Leaf node can be co-located with the RU on the RU side or not, the optical splitter/combiner is part of the PON tree, and the Hub node can either be located in an APN site or co-located with the Dus in the DU site. Optionally an Extra Network QoS-aware packet-based switch can be used between the OLT and the different Dus.

### 3.3. Step 2) Evaluation of feasibility and energy efficiency with Elastic Load Balancing scenario

To evaluate the effectiveness of Elastic load balancing, it is necessary to build an environment that accurately reflects the deployment being tested. This includes the number of RU per RU site and RU sites per DU site. The most significant difference from Step 1 is changing the DU from a real server to a virtual server (shown as “vDU” in Figure 10) to switch between distributed and centralized processing. At the very least, we must prepare two sets of RU and DU. Additionally, multiple UEs will need to be connected to a single RU to fluctuate the traffic volume. From a state where the two sets of RU-DU are communicating, if the traffic of one set decreases, we need to switch the path between RU-DU to the DU where traffic is occurring, establish a new RU-DU connection, and stop the DU that became unnecessary due to the switch. From the S-plane point of view, scenario 4 of IMN document 5.2.6.2, which corresponds to LLS-C3 in O-RAN specification, is suitable for Elastic Load Balancing. In other scenarios, the master clock is located on the DU side, and the master clock changes when the RU connects to another DU host by Elastic Load Balancing, whereas in Scenario 4, the time can always be synchronized with the same master.

- Although DU interface must comply with O-RAN, it does not necessarily need to be virtualized RAN.
- Minimum number of devices
  - RU site : 2
  - RU per RU site : 1
  - DU site : 2
  - DU per DU site : 1
  - RU site per DU site : 1
- Traffic volume from UE: Vary from daytime to nighttime.
- Time synchronization scenario :  
Scenario 4 in IMN document 5.2.6.2, which is correspond to LLS-C3 (shown in Figure 9)

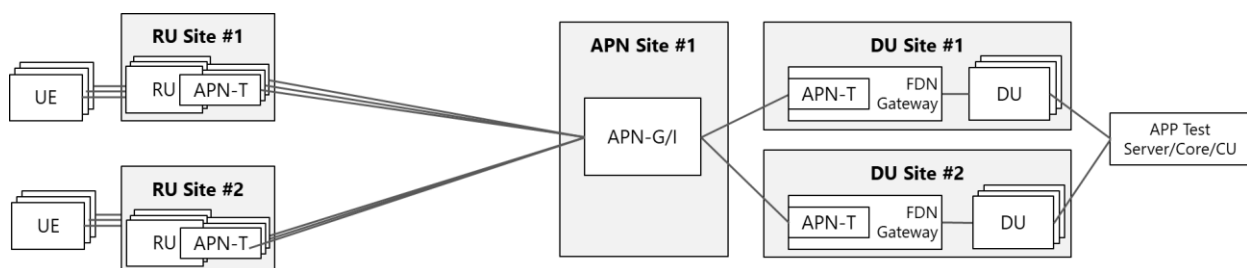

Figure 9 Deployment scenario for step 2

For the end-to-end DWDM technology, the deployment scenario in step 2 looks as follows.

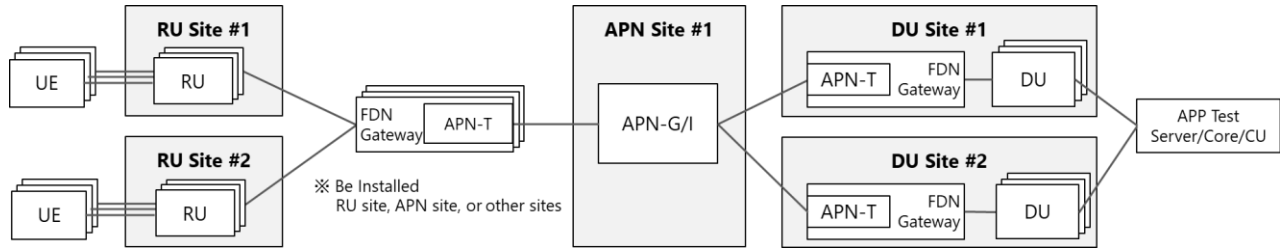

Figure 10 Deployment scenario for step 2

For the PtMP topology the deployment scenario in Step 2 looks as follows (the use of APN-G depends on the Point-to-Multipoint technology):

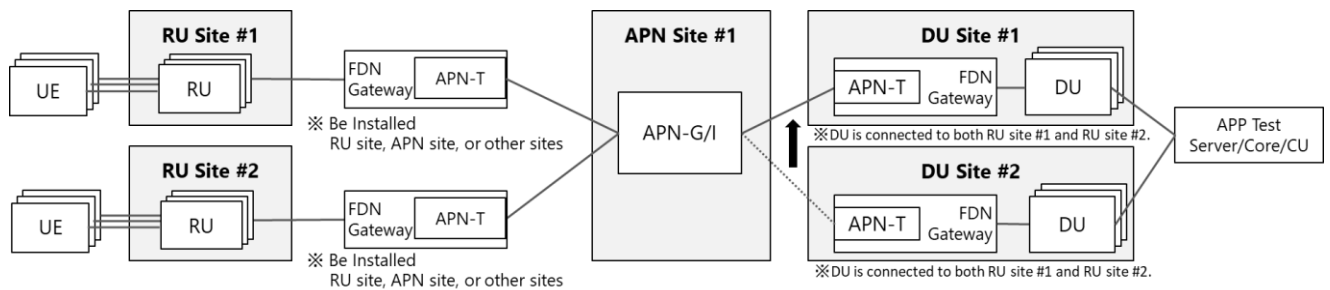

Figure 11 PtMP topology of the deployment scenario in Step 2

The distribution of the S-plane is specific in the case of TDM-PON; following LLS-C3, there is a separate input of PTP and SyncE in a separate interface of the OLT. The time and frequency synchronization are distributed to the ONUs using TDM PON-specific mechanisms (resp. OMCI and 8kHz). The PTP and SyncE are then regenerated at the ONUs and moved towards the RUs. The TDM PON system (OLT & ONU) acts as a distributed T-BC.

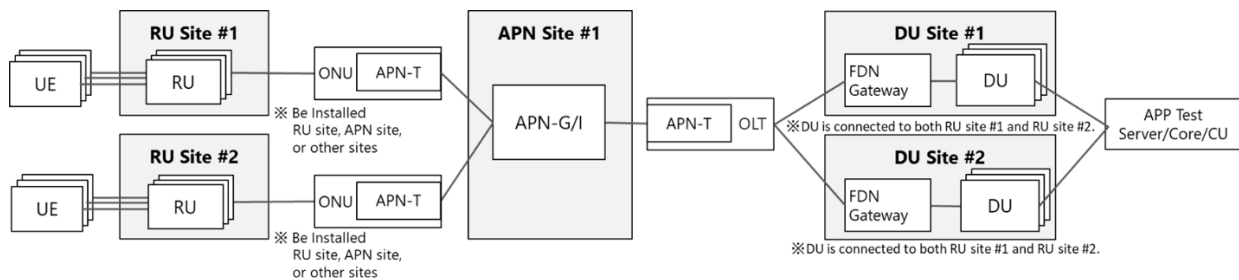

Figure 12 Synchronization distribution with TDM PON technology

## 4. Technical Requirements

### 4.1. Applicable to entire PoC scenarios.

#### 4.1.1. Mobile X-haul [2]

Mobile X-Haul must comply with requirements, for example Table 1 as per the document “Technical Outlook for Mobile Networks Using IOWN Technology 1/27/2022.

*Table 1 a set of requirements for Mobile X-Haul*

	FH			MH		BH	
Interface	CPRI / eCPRI			Control Plane: F1-C, E1, Xn-C  User Plane: F1-U, Xn-U		Control Plane: N1, N2, N4  User Plane: N3, N9	
Connectivity Requirements	—			Multi-point		Multi-point	
Option	WDM	Ether***	IP***	Ether*	IP**	Ether*	IP**
Scale / Distance	0km - 30km			100km order		More than 100,000 RUs	
Slicing	—			1K slices, with delay and availability assurance, and isolation			
Protection / restoration	Protection			50ms protection of connectivity			
Peak data rate	25Gbps – 75Gbps			From a few Gbps to 70Gbps per RU			
Frame delay (One way)	25us – 160us			1.5ms – 10ms		1ms – 50ms	
Frame Loss Ratio (One way)	10 <sup>-7</sup>			N/A		N/A	
PDV	10us			N/A		N/A	
Synchronization accuracy	65ns			N/A		N/A	

#### 4.1.2. Interfaces [3]

In Interfaces, the requirements must comply with the following.

(1)Optical interface between APN-T and APN-G :

1. In the case Flexible Bridging Service is used for aggregating several RUs,
  - W 100-200G 31.6 Gbaud of Open ROADM MSA Optical Specification Version 5.0

- W 200-400G 63.1 Gbaud of Open ROADM MSA Optical Specification Version 5.0
2. In the case RUs connect to APN directly,
- NRZ 10G (N, W) of ITU-T G.698.2
  - NRZ 2.5G (N, W) of ITU-T G.698.2
  - However, this is not limited depending on the optical interfaces supported by the RU side.

(2)O-RAN interface between RU and DU :

O-RAN Alliance Fronthaul Working Group Control, Synchronization Plane Specification, Release 2.00, 2019.

- Ethernet (for transporting eCPRI and PTP/SyncE)
- CPRI IEEE- 1914.3 (for transporting CPRI over a packet-based infrastructure)
- S/C/U-Plane

## **4.2. Applicable to partial PoC scenarios.**

### **4.2.1. Transmission characteristics of optical components**

The requirement for insertion loss of optical splitter-combiner is described in 5.4.1 of ITU-T G.671.

## 5. Key Features

Most of the items described in this section are required for Step 2.

### 5.1. Dynamic Path Switching for Elastic Load Balancing

Dynamic Path Switching for Elastic Load Balancing is a method for dynamically reconfiguring the paths between RUs and DUs based on the increase and decrease of traffic during day and night, as illustrated in Figure 3. This section describes the key features of implementing Optical Switching and Packet Switching in both PtP (Point-to-Point) and PtMP (Point-to-Multipoint) topologies.

#### 5.1.1. Optical path switching

##### 5.1.1.1. PtP topology

The APN-G switches the optical path between the FDN Gateway and the DU host as the vDU is reconfigured due to the aggregated throughput per DU fluctuations. In the case of

Figure 13, usually, the upper RU site connects to the upper DU host, and the lower RU site connects to the lower DU host. As the workload on the DU side decreases, it concentrates processing on the upper DU host. At the same time, APN-G switches the optical path from the connection to the lower DU host to the upper DU host.

- Pros: Energy efficiency, QoS deterministic
- Cons: Transceiver cost, dependency on the speed of APN control

The trigger to switch the optical path is as follows:

The extended cooperative transport interface (eCTI) reported in [2] is one example of solutions for obtaining the trigger to switch optical path. For instance, this PoC can be considered an integrated controller for both mobile networks and APNs. This local controller placed in the DU site collects the performance metrics of vDUs and DU hosts via eCTI. After analyzing the performance metrics, the local controller determines which DU host will be shut down and which optical path of APN-G will need to be switched. One of the simplest examples of the performance metrics is the mobile midhaul data rate, which is equivalent to aggregated throughput per DU host. For instance, we assume that midhaul capacity per DU host is 100 Gbps. The local controller triggers the DU host's shutdown and optical path switching if the sum of the midhaul data rate of the DU host to be shut down and the DU host to accommodate the move-over traffic is 100 Gbps or less. The actual threshold value will also consider traffic burst to avoid triggering the switching too early. The eCTI is also helpful for other purposes such as jitter reduction proposed in [7], targeting 100 ns to 1 ms [2].

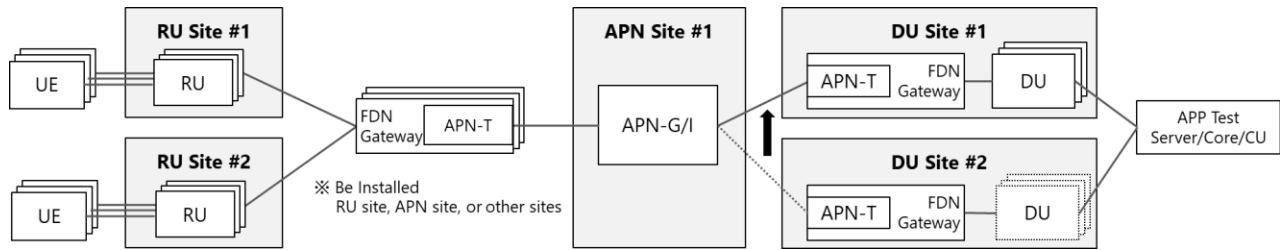

Figure 13 Optical switching-based method

### 5.1.1.2. PtMP topology

The optical path switching also applies to the PtMP topology as drawn in Figure 14. Apart from the topology, the rest is the same as those described in 5.1.1.1.

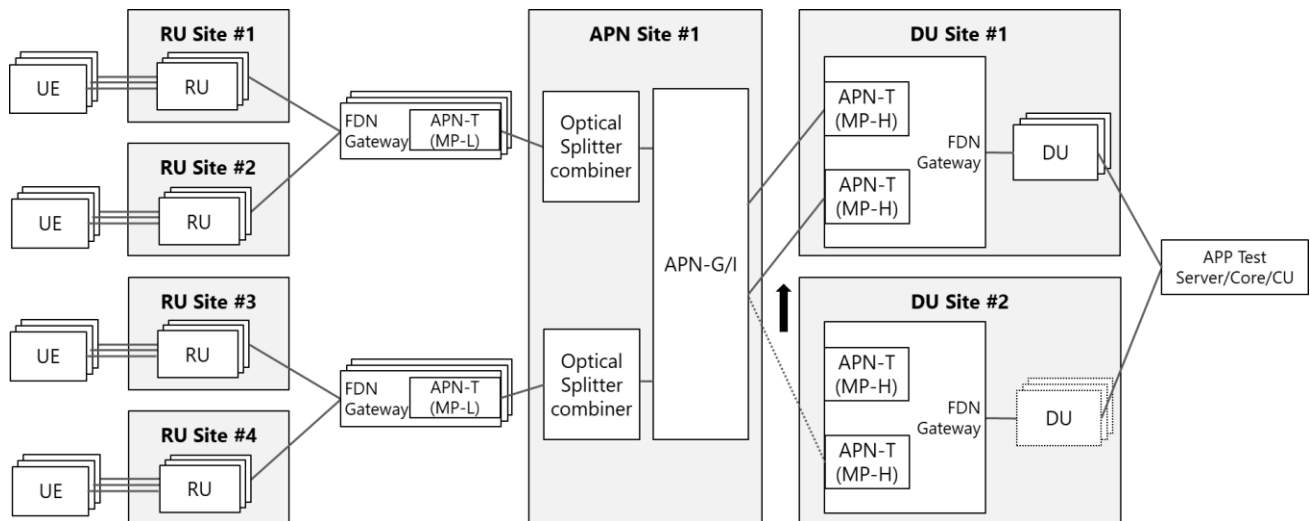

Figure 14 Optical switching-based method (PtMP topology)

## 5.1.2. Packet switching

### 5.1.2.1. PtP topology

The FDN Gateway switches the L2 path between the FDN Gateway and the DU host as the vDU is reconfigured due to the aggregated throughput per DU fluctuations. In the case of Figure 15, usually, the upper RU site connects to the upper DU host, and the lower RU site connects to the lower DU host. As the workload on the DU side decreases, it concentrates processing on the upper DU host. At the same time, FDN Gateway switches the L2 path from connection to the lower DU host to connection to the upper DU host.

- Pros: Transceiver cost (less stand-by transceivers)
- Cons: Energy consumption and QoS indeterministic

The trigger to switch paths is as follows:

The eCTI is one solution for the trigger to switch path as with 5.1.1.1, except that the switching path is not an optical path but an L2/L3 path.

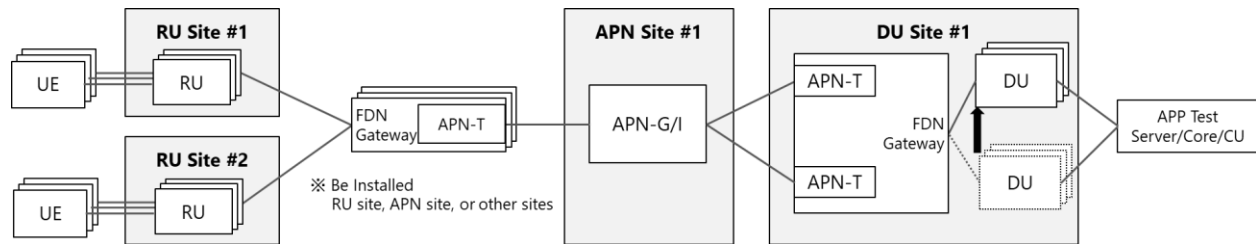

Figure 15 Packet switching-based method

### 5.1.2.2. PtMP topology

In the PtMP method, the Hub node switches the Layer 2 path between the Leaf nodes and the DU host as the vDU is reconfigured due to the aggregated throughput per DU fluctuations. Note that the RUs can be connected to the same PON (as shown in this figure) or across multiple PONs.

In Figure 16 the lower RU site starts being connected to the lower DU host, and the upper RU site is connected to the upper DU host. As the workload on the lower DU side decreases, it concentrates processing on the upper DU host. At the same time, the Hub node switches the Layer 2 path of the ONUs of the lower RU site connected from the lower DU host to the upper DU host. This is indicated by a black arrow between the DU hosts (the traffic flows of the lower RU site are changed by the Hub node from the L2 path to the lower DU host (in DU site 2) to the L2 path to the higher DU host (in DU site 1)). There is no change in the optical PtMP path between the Leaf nodes and the Hub node.

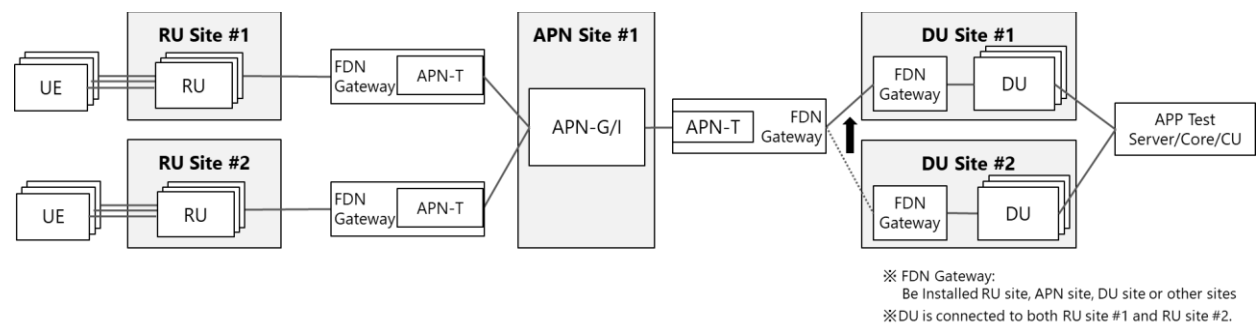

Figure 16 Packet switching-based method (PtMP topology)

- Pros: Transceiver cost and lower power consumption (less transceivers; single PtMP transceiver at OLT for multiple RUs)
- Cons: QoS performance depends on use case.

## **5.2. Dynamic configuration change of NFVI**

It is out of scope, but trigger and how to synchronize with path switching are essential.

## 6. Key Benchmarks

### 6.1. Step 1) Evaluation of feasibility of Mobile Fronthaul over APN scenario

#### 6.1.1. Feasibility based on IMN document

##### Step:

- (1) Equipment such as Open APN equipment and fiber drums between the RU site and the DU site is necessary to extend the distance (nearly 30km) and measure the external network's latency and jitter.
- (2) It is necessary to verify whether the sequences of S/C/U-Plane are successfully completed according to the O-RAN standard.
- (3) It is necessary to measure the uplink and downlink throughput of the U-Plane with and without the APN device.

##### Environmental Conditions :

- (1) Devices
  - RAN devices (RU, DU, CU)
    - Physical device. Although DU interface needs to comply with O-RAN, it does not necessarily need to be a virtualized RAN.
    - APN devices (APN-I, APN-G, APN-T, Flexible Bridge)
    - Physical device. All APN devices comply with the APN technology defined by the OAA.
    - Other device (UE, Packet simulator, etc.)
  - Physical, simulator, emulator, and software-defined nodes are allowed.
- (2) Minimum number of devices
  - RU site : 2
  - RU per RU site : 1
  - DU site : 2
  - DU per DU site : 1
  - RU site per DU site : 1
- (3) Others
  - Traffic volume from UEs: Traffic flow is necessary, regardless of whether it is fixed or fluctuating.
  - Time synchronization scenario: Either LLS-C2/C3/C4

##### Measuring Method:

The measurement method is not specified, i.e., it can use Network tester, or a Sequence monitor, or Packet simulator, etc. However, it is necessary to document clearly the tool used.

**Evaluation Method:**

- (1) Compare the measured data with the O-RAN interface, and show to what extent MFH can be extended.
- (2) Confirm whether the sequences of the S/C/U-Plane have been successfully completed, such as whether PTP synchronization processing, cell setting processing, and U-Plane traffic are flowing.
- (3) Measure the uplink and downlink throughput of user data, with and without the APN device, and compare them to confirm that they are the same.

**6.2. Step 2) Evaluation of feasibility and energy efficiency with Elastic Load Balancing scenario**

**6.2.1. Step 2-1 Feasibility**

**Step:**

- (1) Clarify the procedure from the communication state of RU-DU to the switching to a new RU and DU communication state. The procedure includes DU shutdown decisions triggered by performance monitoring.
- (2) Clarify the time taken for the path switching.
- (3) Clarify the impact of the content and time of service from the perspective of users and carriers when switching.

**Environmental Conditions :**

- (1) Devices
  - RAN devices (RU, DU, CU)
  - Physical device, simulator, emulator. All vRAN devices must comply with the O-RAN specifications.
  - APN devices (APN-I, APN-G, APN-T, Flexible Bridge)
  - Physical device. All APN devices comply with the APN technology defined by the OAA.
  - Other device (UE, Packet simulator, etc)
  - Allow physical, simulator, emulator, and software as necessary.
- (2) Minimum number of devices
  - RU site : 2
  - RU per RU site : 1
  - DU site : 2
  - DU per DU site : 1
  - RU site per DU site : 1
- (3) Others
  - Traffic volume from UEs: Consider daytime and nighttime traffic fluctuations.

- Time synchronization scenario: Either LLS-C2/C3/C4

**Measuring Method:**

- (1) Confirm whether this model can be carried out according to the procedure. Ensure that the communication between RU and DU is functions normally before and after the switch.
- (2) Measure the working time for each procedure when switching.
- (3) Obtain data of the S/C/U-Plane sequence during the switching, and the U-Plane's Uplink and downlink throughout.

**Evaluation Method:**

- (1) Check whether the switch implementation procedure was appropriate (for instance, there were no unforeseen impacts on service or extensions to the service time).
- (2) Verify if the time taken for the switch is acceptable (consider if there are any opportunities or methods to reduce the work duration).
- (3) Confirm whether the nature and timing of the impact on service during the switch are suitable (evaluate if the degree/content of the impact on service is feasible as a use case, and determine if there are any technical issues).

### 6.2.2. Step 2-2 Energy efficiency

**Step:**

Clarify the effects, such as the reduction in power consumption and the number of vDUs, when using APN wavelength path switching to put vDU sites into sleep mode during low traffic. In a case where a wide area with RU-DU distance of 30 km combines, a business district with high daytime traffic and low nighttime traffic and a residential area where the opposite is the case, ensure these are accommodated by multiple vDUs.

**Environmental Conditions :**

As it is necessary to prepare about 100 RUs and more than ten vDUs, collecting basic data on a small scale and carrying out large-scale simulations is permissible.

Therefore, the following conditions are set for obtaining basic data on a small scale.

- (1) Devices
  - RAN devices (RU, DU, CU)
  - Physical device, simulator, emulator. All vRAN devices must comply with the O-RAN specifications.
  - APN devices (APN-I, APN-G, APN-T, Flexible Bridge)
  - Physical device. All APN devices complied with the APN technology defined by the OAA.
  - Other device (UE, Packet simulator, etc.)
  - Allow physical, simulator, emulator, and software as necessary.

(2) Minimum number of devices

- RU site : 2
- RU per RU site : 1
- DU site : 2
- DU per DU site : 1
- RU site per DU site :
- One method of calculating the effects of ELB may involve using the number of RUs and DUs housed in the original base as a reference when the distance between them is expanded to 30km.

For instance, it is conceivable that there are about 100 RUs in urban areas, about 100 RUs in residential areas, and about 20 DUs.

(3) Others

- Time synchronization scenario: LLS-C2/C3/C4

**Measuring Method:**

(1) Measure the energy consumption of vRAN devices and APN devices both with and without the use of the Elastic Load Balancing feature.

(2) Since traffic needs to fluctuate during energy consumption measurement, the ETSI document [8] is used as a reference and three traffic load models are defined: low, medium, and busy-hour.

Set the number of UEs (terminals) during low (72), medium (96), and busy-hour (160) periods. However, the number of UEs can be adjusted according to regional traffic characteristics. Also, consider the traffic variations for business districts (daytime peak) and residential areas (night-time peak).

(3) The timing threshold value for switching APN and RAN equipment according to traffic using the Elastic Load Balancing feature can be set based on regional traffic characteristics.

(4) The number of UEs, file size, and transmission intervals can be set according to the traffic characteristics of the respective area. The settings should be documented in the PoC Report. Additionally, describe in the PoC Report the traffic variation and switching timing for both business districts (daytime peak) and residential areas (night-time peak). If further reference information is needed, sections 6.3.3 to 6.3.8 in the ETSI document [8] related to the DATA traffic model and Appendix C can be helpful.

(5) The efficiency measurement of the base station (BS) should be performed when the internal temperature conditions of the equipment have become stabilized. For additional reference information, sections 6.3.9 "Power and Energy Consumption Measurements" to 6.3.10 "Energy Consumption Measurements" in the ETSI document [8] can be helpful.

Examples of settings for (1) to (5) will be provided as reference information in Appendix V.

**Evaluation Method:**

- (1) Compare the daily power consumption before and after the APN implementation during the operation of Elastic Load Balancing and quantify the effect. The daily power consumption should be the total energy consumption at each traffic level, i.e., during low, medium, and busy-hour traffic levels. If measurements can be obtained for the entire 24-hour period, it is not necessary to measure throughout for the entire day. The daily power consumption can be calculated based on data collected under various conditions.
- (2) Compare the maximum and minimum number of DUs and consumed resources during the operation of Elastic Load Balancing and quantify the effect.

## Conclusions

This document includes Purpose, Objective, Reference Cases, Technical Requirements, Key Features and Key Benchmarks about Mobile Fronthaul over APN PoC. The PoC needs to be reported based on this PoC Reference document.

Any insights or technical issues detected during the implementation of the PoC should be recorded in the PoC Report.

When creating a PoC report, it is necessary to use the report templates specified by IOWN Global Forum [9].

## References

[1]	IOWN Global Forum Use Cases: <a href="https://iowngf.org/use-cases/">https://iowngf.org/use-cases/</a>
[2]	Technical Outlook for Mobile Networks Using IOWN Technology: <a href="https://iowngf.org/wp-content/uploads/formidable/21/IOWN-GF-RD-Technical-Outlook-for-Mobile-Networks-1.0-1.pdf">https://iowngf.org/wp-content/uploads/formidable/21/IOWN-GF-RD-Technical-Outlook-for-Mobile-Networks-1.0-1.pdf</a>
[3]	Open All-Photonic Network (APN) Functional Architecture: <a href="https://iowngf.org/wp-content/uploads/formidable/21/IOWN-GF-RD-Open-APN-Functional-Architecture-2.0.pdf">https://iowngf.org/wp-content/uploads/formidable/21/IOWN-GF-RD-Open-APN-Functional-Architecture-2.0.pdf</a>
[4]	3GPP TR 38.801 Release 14: “Radio access architecture and interfaces”.
[5]	O-RAN Fronthaul Interoperability Test Specification (IOT) 6.01
[6]	ETSI TS 103 859 V7.0.2 (2022-09) Publicly Available Specification (PAS); O-RAN Fronthaul Control, User and Synchronization Plane Specification v07.02; (O-RAN.WG4.CUS.0-v07.02)
[7]	Technical Outlook for Mobile Networks Using IOWN Technology - Advanced Transport Network Technologies for Mobile Network <a href="https://iowngf.org/wp-content/uploads/formidable/21/IOWN-GF-RD-IMN-PHSE2-1.0.pdf">https://iowngf.org/wp-content/uploads/formidable/21/IOWN-GF-RD-IMN-PHSE2-1.0.pdf</a>
[8]	ETSI TS 103 786 V1.1.1 (2020-12) Environmental Engineering (EE);Measurement method for energy efficiency of wireless access network equipment;Dynamic energy efficiency measurement method of 5G Base Station (BS): <a href="https://www.etsi.org/deliver/etsi_ts/103700_103799/103786/01.01.01_60/ts_103786v010101p.pdf">https://www.etsi.org/deliver/etsi_ts/103700_103799/103786/01.01.01_60/ts_103786v010101p.pdf</a>
[9]	IGF_PoC_report_template <a href="https://iowngf.atlassian.net/wiki/spaces/TWG/pages/2147319845/PoC+Report+Submission+Page">https://iowngf.atlassian.net/wiki/spaces/TWG/pages/2147319845/PoC+Report+Submission+Page</a>

## History

Revision	Release Date	Summary of Changes
1	August 2022	Initial Release
2	August 2024	Version 2.0

## Appendix I: Definition of Benchmark-First PoC

### 1. Reference cases

This chapter is provided as an alternative definition for Chapter 3 in the main body.

Replace the parts related to RIM, such as implementation and deployment forms, in Chapter 3 of the main text, with the following.

This is a basic scenario for conducting a PoC in the Elastic Load Balancing use case. As stated in section 2.2, the PoC scenario aims to show the quantitative effect in the case where the DU site accommodates a wide range of RUs, including business districts and residential areas (up to a maximum of 30km), and operates with the necessary number of vDUs according to the number of UEs and the amount of traffic during the day and night. Therefore, as shown in Figure 17, having multiple DU sites and accommodating business districts and residential areas over a wide area is an important point in demonstrating the effects of the use case. Based on this scenario, we will describe the deployment method of the APN device (such as whether to place the APN device at the RU site or the DU site, or how to configure the topology) in the PoC Report for both Step 1 and Step 2.

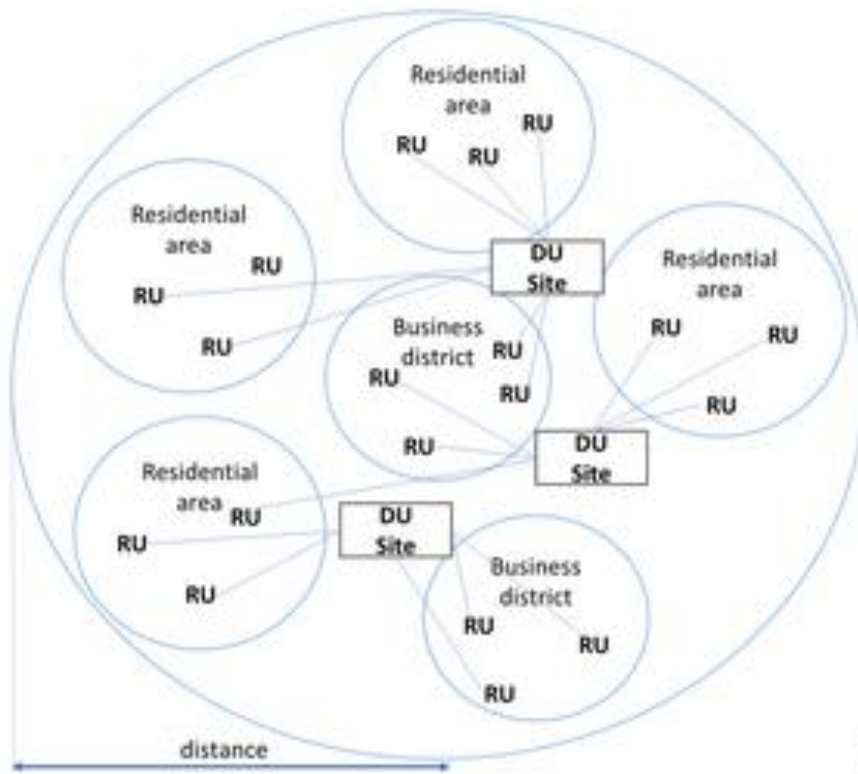

Figure 17 Reference cases

## **2. Key features**

Dynamic Path Switching for Elastic Load Balancing is a method for dynamically reconfiguring the paths between RUs and DUs based on the increase and decrease of traffic during day and night, as illustrated in Figure 3.

This chapter is provided as an alternative definition for Chapter 5 in the main body.

Replace the parts related to RIM, such as implementation and deployment forms, in Chapter 5 of the main text, with the following content.

This document does not define the method of switching the connected DU of the RU in the APN device or the method of determining the switch timing.

## **3. Other**

Refer to Chapters 1, 2, 4 and 6.

Whether the approach is Benchmark-First or RIM-First, the effects of the Elastic Load Balancing use case need to be summarized in the PoC report. Moreover, it is desirable that these results be comparable under the same conditions. The Measuring Method and Evaluation Method are the same for Benchmark-first and RIM-first approaches.

## Appendix II: Switching method that minimizes service impact

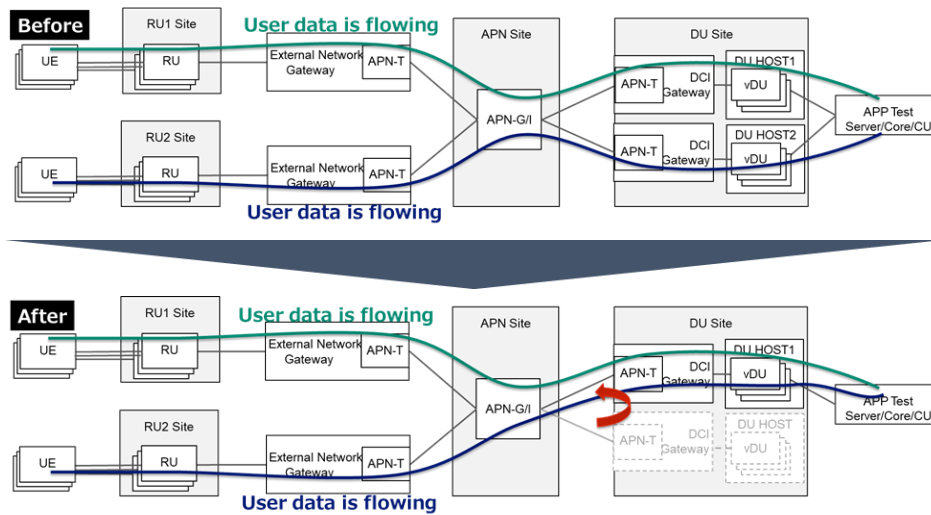

Figure 18 a switching method that minimizes service impact

**We must consider a switching method that minimizes service impact as much as possible.**

- To minimize the impact on user traffic from RU2 - DU Host2, work on the devices on both the RU and DU sides is required.
- Work is required on the devices to switch the path of RU2's APN from DU Host2 to DU Host1.
- DU setting on the DU Host1 side is necessary in advance to shorten the switching over time.
- It is necessary that switching will not affect the U-Plane being connected between RU1 and DU Host1.

### Appendix III: Single-fiber bidirectional access architecture

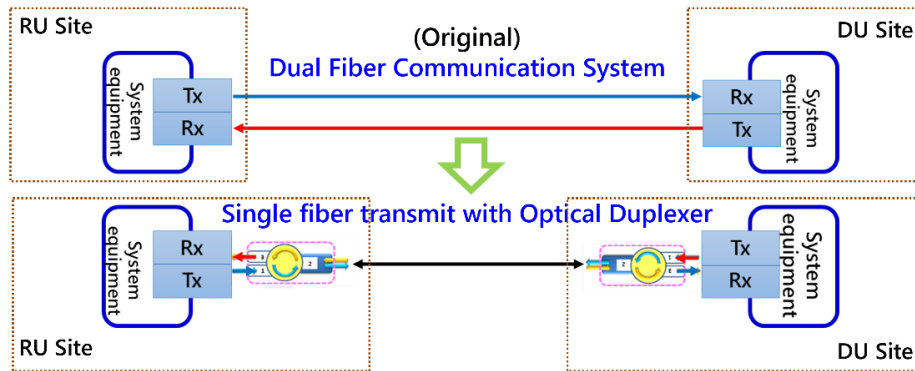

Figure 19 Single-fiber bidirectional access architecture

Single-fiber bidirectional access architecture is considered for the following reasons:

- Saving the fiber resources between the RU and DU sites.
- Using an optical duplexer or other passive optical component is acceptable.
- No additional power supply is needed.
- Reducing/eliminating synchronization error introduced by asymmetric delay of unequal optical transport paths.

The purpose of Single-fiber bidirectional access architecture for reducing synchronization time error is to meet the synchronization requirements as follows for 5G based on 3GPP Technical Specification (TS) Standard.

- Frequency synchronization  $\leq \pm 50\text{ppb}$
- Phase synchronization  $< \pm 1500\text{ns}$

Figure 20 shows downlink and uplink fiber paths for mobile fronthaul. When the fiber length difference between downlink distance  $D_1$  and uplink distance  $D_2$  exceeds 0.6km, it introduces Phase synchronization error  $> \pm 1500\text{ns}$ , which surpasses synchronization requirement limit.

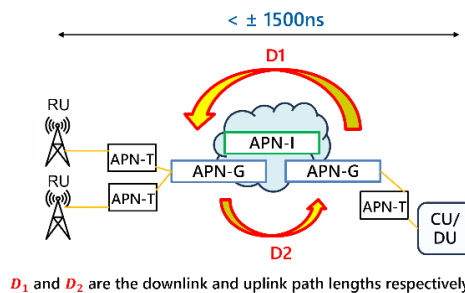

Figure 20 Downlink and uplink fiber paths for mobile fronthaul

## Appendix IV: Packet-optical for Load Balancing and RAN Sharing Model

This model aggregates, the RUs and DUs traffic in packet nodes (L2 switches or routers). Such packet flows are then multiplexed into one or more wavelengths by the APN-T block before being transported via the APN. Two RU Sites and two DU sites are geographically separated and connected by the APN.

The reference case for the PoC is the combination of the following two functionalities:

- **MNO RAN sharing.** It is considered that two MNOs, namely MNO A and MNO B in Figure 21, own their DUs. RUs can be owned or shared. For example, RU1 is shared by MNO A and MNO B while RU 2 is owned by MNO A. In the case of shared, dedicated RU interface for MNO is considered.
- **Elastic Load Balancing** for the reducing energy consumption, as described in section 3 and detailed in the Appendix I “Reference cases”. DUs’ deactivation (switch off/sleep) is considered by exploiting opportunities for baseband processing consolidation.

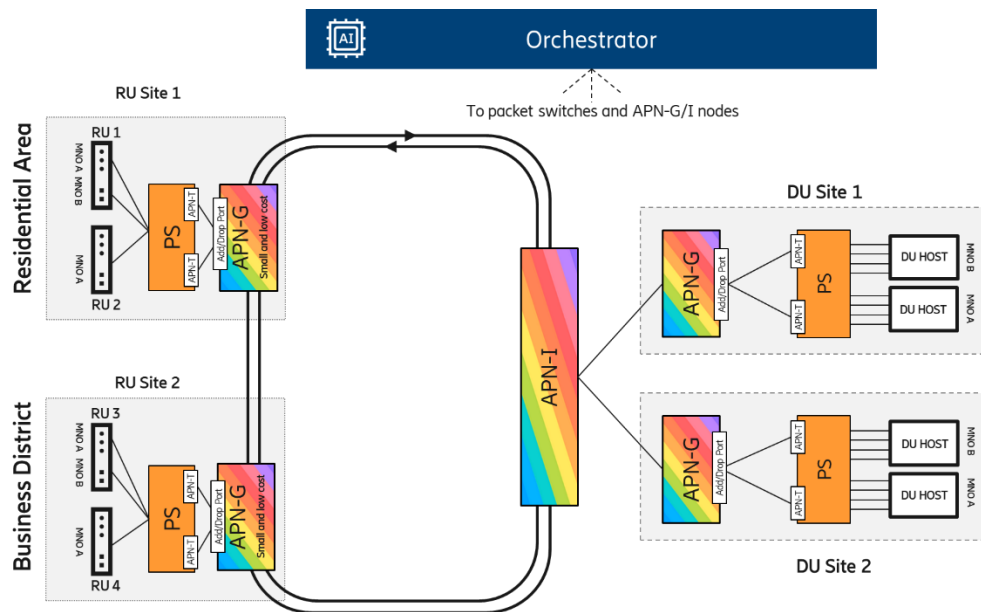

Figure 21 Multi-operator scenario in the extended demo

The pros and cons from the perspective of RAN Sharing are as follows. Please note that there are also pros and cons for Elastic Load Balancing, which are equivalent to those stated in the main text.

-Pros

Cost-efficiency of APN equipment investment.

Decreasing the number of unused ports on APN equipment can reduce the unit price per port.

-Cons

Deployment restrictions.

RAN Sharing service forms the basis, but its implementation is limited to a format introduced by Sharing operators or TowerCo, rather than one introduced by carriers.

The following is provided as additional explanation for the aforementioned pros and cons.

Pros: Until now, we have considered models where each carrier uses the Flexiblebridge, APN-T/G/I exclusively. In this scenario, each carrier must plan to fill up the available ports on each APN equipment to avoid any unused ports. If there are unused ports, the cost efficiency of the equipment deteriorates.

However, it is difficult to actually deploy in all areas without leaving unused ports. (This is especially true in rural areas where there are few base stations.)

Therefore, by sharing the APN equipment with multiple MNO carriers, it becomes easier to eliminate unused ports.

Cons: Until now, we have considered models where each carrier uses the Flexiblebridge, APN-T/G/I exclusively. However, if carriers share a fixed network, each carrier must introduce APN equipment.

It is difficult to share across carriers in this case. (There is a possibility of sharing in rural areas, etc.)

Therefore, it is restricted to a kind of operation introduced by sharing operators or TowerCo.

Key Feature

The **Orchestrator**, which is responsible for managing packet switches, APN-Gs and APN-I, ensures a key feature. The orchestrator includes an **AI-based** module that examines the traffic data collected at monitoring points located at the ingress side of the packet switches and can predict future traffic trends.

The role of the orchestrator is reported in the following in the two mentioned functionalities:

- In **MNO RAN sharing**, each MNO is assigned a transport slice, which could include several transport connections. The orchestrator uses the AI-based module to manage congestion in packet switches, ensure E2E latency limits are satisfied, and to facilitate dynamic traffic switching in response to changing traffic demands.
- In **Elastic Load Balancing**, for each MNO slice, the orchestrator can adapt to traffic variations in residential and business districts served by the corresponding RUs at various times. The traffic prediction made by the AI-based module is used to optimally setting up packet nodes, manage congestion within these nodes, determine the most efficient transport route, and adjust the transport path's bandwidth as needed.

- The orchestrator allows the MNO to dynamically and automatically configure the APN switches to ensure guarantee QoS (e.g., E2E latency, packet loss) by controlling the congestion in each packet node in the radio site and as E2E paths in the APN equipment. Without such orchestration function the QoS should be assured by high overprovisioning of the network resources.

## Appendix V: Definition of Traffic Model and Power and Energy Consumption Measurement

### 1. Data Traffic model

- Set the number of UEs (User Equipment) during the LOW (72)/Medium (96) and Busy-hour (160) periods in the traffic load model.
- The number of UEs per hour for business districts (with peak during the day) and residential areas (with peak at night) will be as follows.
- The file size should be set at 1kByte. Inter-arrival time should be set at 20ms.

Table 2 Data Traffic model

Hour	0	1	2	3	4	5	6	7	8	9	10	11	12	13	14	15	16	17	18	19	20	21	22	23	24
Business District	72	72	72	72	72	72	72	96	96	96	160	160	160	160	160	160	160	160	96	96	96	72	72	72	72
Residential area	96	96	72	72	72	72	96	160	160	96	72	72	72	72	72	72	72	72	96	160	160	160	160	96	96

### 2. Power and Energy Consumption Measurement

- The Base Station (BS) efficiency measurements shall be performed when stable temperature conditions inside the equipment are reached. The equipment must be operated for at least one hour before the measurements are conducted.
- After changing the traffic load, apply a minimum operation time of 1 hour again before carrying out measurements anew.
- To carry out evaluations, we need to calculate the total power usage over 24 hours. However, it's unnecessary to measure power continuously for a full day, if we can otherwise obtain a 24-hour measurement.

To determine the total power usage over 24 hours, there are several possible approaches:

- One approach involves considering various traffic models - Low, Middle, and Busy-Hour - and measuring the power usage for one hour under each model. Meanwhile, the power usage of one side can be measured while the DU is in Sleep mode, taking the traffic into consideration. These measurements can then calculate the total power usage over 24 hours.
- Another method is to simulate the variation in traffic over 24 hours within a shorter time frame, such as 6 hours, and extrapolate this data to represent total power usage for a full day.
- ✖Therefore, we propose to shorten the new table titled "The number of UEs per hour" to 6 hours and then simply multiply the measured results by four to calculate the power consumption for an entire 24-hour period.