



IOWN
GLOBAL FORUM™

PoC Reference: Reference Implementation Model for the Interactive Live Music Entertainment Use Case

Classification: APPROVED REFERENCE DOCUMENT

Confidentiality: Public

Version 1

December 2023

[RIM for ILM UC PoC Reference]

Legal

THIS DOCUMENT HAS BEEN DESIGNATED BY THE INNOVATIVE OPTICAL AND WIRELESS NETWORK GLOBAL FORUM, INC. ("IOWN GLOBAL FORUM") AS AN APPROVED REFERENCE DOCUMENT AS SUCH TERM IS USED IN THE IOWN GLOBAL FORUM INTELLECTUAL PROPERTY RIGHTS POLICY (THIS "REFERENCE DOCUMENT").

THIS REFERENCE DOCUMENT IS PROVIDED "AS IS" WITH NO WARRANTIES WHATSOEVER, WHETHER EXPRESS, IMPLIED, STATUTORY, OR OTHERWISE, INCLUDING WITHOUT LIMITATION ANY WARRANTY OF MERCHANTABILITY, NONINFRINGEMENT OF THIRD PARTY RIGHTS, TITLE, VALIDITY OF RIGHTS IN, FITNESS FOR ANY PARTICULAR PURPOSE, OR ANY WARRANTY OTHERWISE ARISING OUT OF ANY PROPOSAL, REFERENCE DOCUMENT, SAMPLE, OR LAW. WITHOUT LIMITATION, IOWN GLOBAL FORUM DISCLAIMS ALL LIABILITY, INCLUDING WITHOUT LIMITATION LIABILITY FOR INFRINGEMENT OF ANY PROPRIETARY RIGHTS AND PRODUCTS LIABILITY, RELATING TO USE OF THE INFORMATION IN THIS REFERENCE DOCUMENT AND TO ANY USE OF THIS REFERENCE DOCUMENT IN CONNECTION WITH THE DEVELOPMENT OF ANY PRODUCT OR SERVICE, AND IOWN GLOBAL FORUM DISCLAIMS ALL LIABILITY FOR COST OF PROCUREMENT OF SUBSTITUTE GOODS OR SERVICES, LOST PROFITS, LOSS OF USE, LOSS OF DATA OR ANY INCIDENTAL, CONSEQUENTIAL, DIRECT, INDIRECT, PUNITIVE, EXEMPLARY, OR SPECIAL DAMAGES, WHETHER UNDER CONTRACT, TORT, WARRANTY OR OTHERWISE, ARISING IN ANY WAY OUT OF USE OR RELIANCE UPON THIS REFERENCE DOCUMENT OR ANY INFORMATION HEREIN.

EXCEPT AS EXPRESSLY SET FORTH IN THE PARAGRAPH DIRECTLY BELOW, NO LICENSE IS GRANTED HEREIN, EXPRESS OR IMPLIED, BY ESTOPPEL OR OTHERWISE, TO ANY INTELLECTUAL PROPERTY RIGHTS OF THE IOWN GLOBAL FORUM, ANY IOWN GLOBAL FORUM MEMBER OR ANY AFFILIATE OF ANY IOWN GLOBAL FORUM MEMBER. EXCEPT AS EXPRESSLY SET FORTH IN THE PARAGRAPH DIRECTLY BELOW, ALL RIGHTS IN THIS REFERENCE DOCUMENT ARE RESERVED.

A limited, non-exclusive, non-transferable, non-assignable, non-sublicensable license is hereby granted by IOWN Global Forum to you to copy, reproduce, and use this Reference Document for internal use only. You must retain this page and all proprietary rights notices in all copies you make of this Reference Document under this license grant.

THIS DOCUMENT IS AN APPROVED REFERENCE DOCUMENT AND IS SUBJECT TO THE REFERENCE DOCUMENT LICENSING COMMITMENTS OF THE MEMBERS OF THE IOWN GLOBAL FORUM PURSUANT TO THE IOWN GLOBAL FORUM INTELLECTUAL PROPERTY RIGHTS POLICY. A COPY OF THE IOWN GLOBAL FORUM INTELLECTUAL PROPERTY RIGHTS POLICY CAN BE OBTAINED BY COMPLETING THE FORM AT: www.iowngf.org/join-forum. USE OF THIS REFERENCE DOCUMENT IS SUBJECT TO THE LIMITED INTERNAL-USE ONLY LICENSE GRANTED ABOVE. IF YOU WOULD LIKE TO REQUEST A COPYRIGHT LICENSE THAT IS DIFFERENT FROM THE ONE GRANTED ABOVE (SUCH AS, BUT NOT LIMITED TO, A LICENSE TO TRANSLATE THIS REFERENCE DOCUMENT INTO ANOTHER LANGUAGE), PLEASE CONTACT US BY COMPLETING THE FORM AT: <https://iowngf.org/contact-us/>

Copyright © 2023 Innovative Optical Wireless Network Global Forum, Inc. All rights reserved. Except for the limited internal-use only license set forth above, copying or other forms of reproduction and/or distribution of this Reference Document are strictly prohibited.

The IOWN GLOBAL FORUM mark and IOWN GLOBAL FORUM & Design logo are trademarks of Innovative Optical and Wireless Network Global Forum, Inc. in the United States and other countries. Unauthorized use is strictly prohibited. IOWN is a registered and unregistered trademark of Nippon Telegraph and Telephone Corporation in the United States, Japan, and other countries. Other names and brands appearing in this document may be claimed as the property of others.

Contents

1. Introduction	6
1.1. Purpose	6
1.2. Objective	6
1.3. Scope	6
2. PoC	8
2.1. PoC for Rendering and Video Delivery to Audience Members (PoC-RVD)	8
2.1.1. Overview	8
2.1.2. Selected Features	9
2.1.2.1. Device Requirement.....	9
2.1.2.1.1. Control Device	9
2.1.2.1.2. Renderer Node	10
2.1.2.1.3. Display Devices	10
2.1.2.2. Network Requirement	10
2.1.2.2.1. User Control Data from Audience Member site to Renderer Node	10
2.1.2.2.2. Rendered Video from Renderer Node to Audience Member site.....	11
2.1.2.3. System Requirement.....	11
2.1.2.3.1. Latency	11
2.1.2.3.2. Scalability	11
2.1.3. Advanced Optional Features	12
2.1.3.1. Data Collection via Network and Artist 3D Model Loading	12
2.1.3.2. Point to Multi-Point	12
2.1.3.3. Additional Improvements.....	13
2.1.3.4. Compression Methods	13
2.1.4. Expected Benchmark	14
2.1.4.1. Latency.....	14
2.1.4.2. Required System Resources and Configuration.....	14
2.1.4.3. Energy Efficiency	14
2.1.4.4. Network Resource.....	15
2.1.5. Other Considerations	15
2.2. PoC for Scalable Architecture for Renderer and Virtual Space Management (PoC-SAR).....	15
2.2.1. Overview	16
2.2.2. Selected Features	19

2.2.2.1.	Selected Features for N401 Virtual Space Creator.....	19
2.2.2.2.	Selected Features for N211 Animation Data Generator.....	20
2.2.2.3.	Selected Features for N213 Renderer.....	21
2.2.3.	Advanced Optional Features.....	21
2.2.3.1.	N401 Virtual Space Creator.....	21
2.2.3.2.	N211 Animation Data Generator.....	22
2.2.3.3.	N213 Renderer.....	23
2.2.4.	Expected Benchmark.....	23
2.2.4.1.	Latency.....	24
2.2.4.2.	Scalability.....	24
2.2.4.3.	Data Processing Efficiency.....	25
2.2.5.	Other Considerations.....	25
3.	Summary.....	26
4.	References.....	27
5.	Abbreviations.....	28
6.	Terms and Definitions.....	30
Annex.A.	Implementation Examples for PoC-RVD.....	32
Annex.B.	How to Measure the Motion-to-Photon Latency.....	33
B.1	Motion-to-Photon.....	33
B.2	Click-to-Photon.....	33
B.2.1	Configuration.....	33
B.2.2	Measurement Method.....	34
B.2.3	Analysis with High Frame Rate Camera.....	34
Annex.C.	Scalable Architecture Patterns.....	35
C.1	Possible Architecture Patterns to Build a Scalable Virtual Space Creator Component.....	35
C.1.1	Geo-Distributed Implementation of the Virtual Space Creator Component.....	35
C.1.2	Usage of intelligent clients.....	36
C.2	Comparison among Possible Architecture Patterns of the Scalable Virtual Space Creator Component.....	39
7.	Acknowledgments.....	42
8.	History.....	43

List of Figures

Figure 1.3-1: Scopes of PoCs to evaluate the ILM RIM	7
Figure 2.1-1: Overview of PoC-RVD	8
Figure 2.1-2: Implementation Example	9
Figure 2.1-3: Example of the Open APN PtMP and FDN Functional Architecture between Renderer Node in Edge DC and Audience Node in Audience Member Site(s)	13
Figure 2.2-1: Overview of PoC-SAR	16
Figure 2.2-2: Assumed Physical Configuration of PoC-SAR	17
Figure 2.2-3: Assumed Physical Configuration of N211, N213, and N401 Nodes in PoC-SAR.....	19

List of Tables

Table C2-1: Architecture Pattern Comparison	41
---	----

1. Introduction

1.1. Purpose

To realize use cases proposed by IOWN Global Forum (IOWN GF) satisfying markets demands in a rapid and efficient manner, IOWN GF is taking an iterative approach of

- developing Reference Implementation Models (RIMs) based on the IOWN GF Use Cases,
- executing Proof of Concepts (PoCs) for evaluating the RIM using a defined Benchmark Model, and
- providing results from the executed PoCs for developing specifications and feeding back to the next version of the RIM.

As the first attempt at developing the RIM, Reference Implementation Model for Interactive Live Music Use Case Document (ILM RIM Document) [ILM RIM] defines:

- The Benchmark Model for the Interactive Live Music Use Case (ILM UC) - Metrics for evaluating the implementation models, e.g., motion-to-photon latency, system cost and system power consumption (See the ILM RIM Document for details).
- The initial ILM RIM that yields the best evaluation results for the metrics defined in the Benchmark Model.

Based on the ILM RIM Document, this document provides guidelines for developing PoCs for the ILM UC to evaluate the ILM RIM using the defined Benchmark Model during the iterative process to validate the IOWN GF technologies.

1.2. Objective

Toward the purpose stated in Section 1.1, this document defines the objectives of the PoC for the ILM UC as follows:

- to aid the development of the specifications of IOWN GF technologies satisfying the market's demand in a rapid and efficient manner through the iterative development of the PoCs,
- to implement critical parts of the ILM RIM, which have difficulty to be realized economically with current technologies,
- to measure the metrics related to the latency, jitter, energy consumption, and system cost in a quantitative manner, and
- to find potential technical improvements and provide feedback to future releases of IOWN GF technologies and ILM RIM studies.

Note: This document does not describe detailed implementation or measurement results.

1.3. Scope

To achieve the objectives shown in Section 1.2, this document defines the following PoC scopes that include critical parts of the ILM RIM which can be selected for the development of the PoC.

- PoC for Rendering and Video Delivery to Audience Members (PoC-RVD)
 - Scope: Control Device - Renderer - Display
- PoC for Scalable Architecture for Renderer and Virtual Space management (PoC-SAR)
 - Scope: Animation Data Generator, Renderer and Virtual Space Creator

The scopes of both PoC-RVD and PoC-SAR are shown in Figure 1.3-1 in the context of ILM RIM, which is slightly simplified from the ILM RIM Document for explanatory purpose. The red line is for PoC-RVD and the blue line is for PoC-SAR.

PoC Reference: Reference Implementation Model for the Interactive Live Music Entertainment Use Case

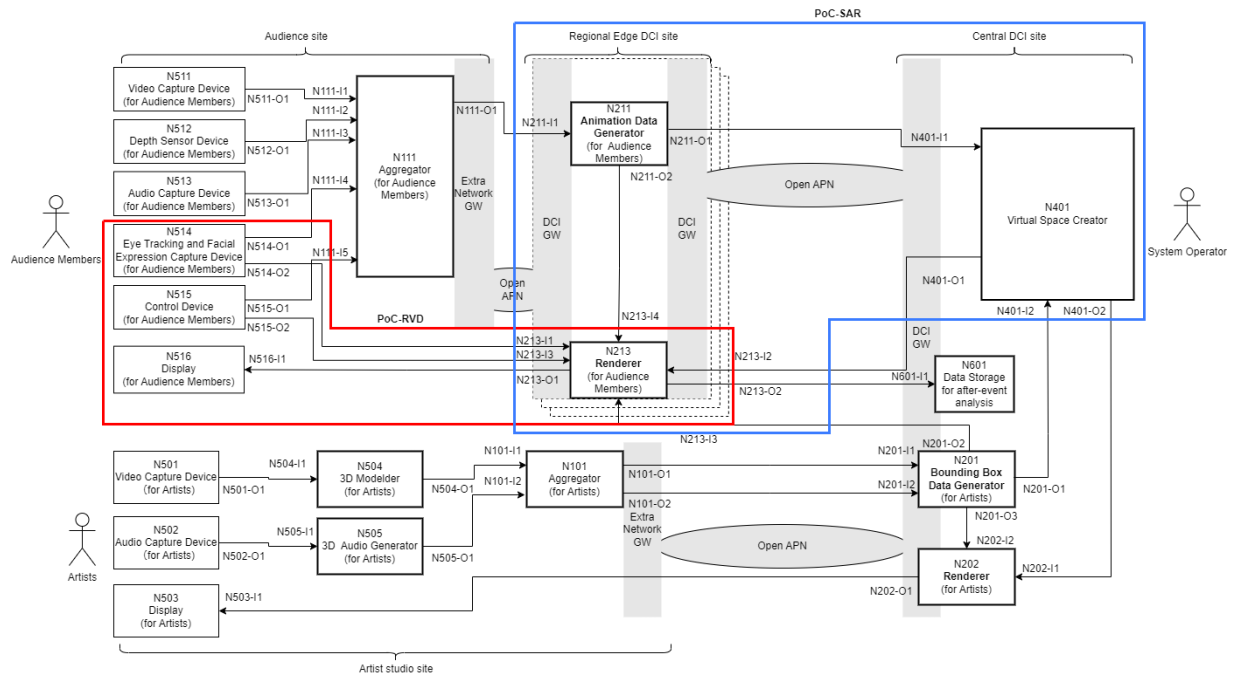

Figure 1.3-1: Scopes of PoCs to evaluate the ILM RIM

This document provides an overview of the PoC, selected features, advanced optional features, and the expected benchmark.

2. PoC

2.1. PoC for Rendering and Video Delivery to Audience Members (PoC-RVD)

The overview of PoC-RVD is provided in Section 2.1.1. Selected features for the PoC-RVD are discussed in Section 2.1.2. All the PoC Reports at least need to cover the features defined in Section 2.1.2. Then, the advanced optional features for the PoC are highlighted in Section 2.1.3. Finally, the expected benchmark of the PoC and other considerations that should be considered are described in Section 2.1.4 and Section 2.1.5, respectively.

2.1.1. Overview

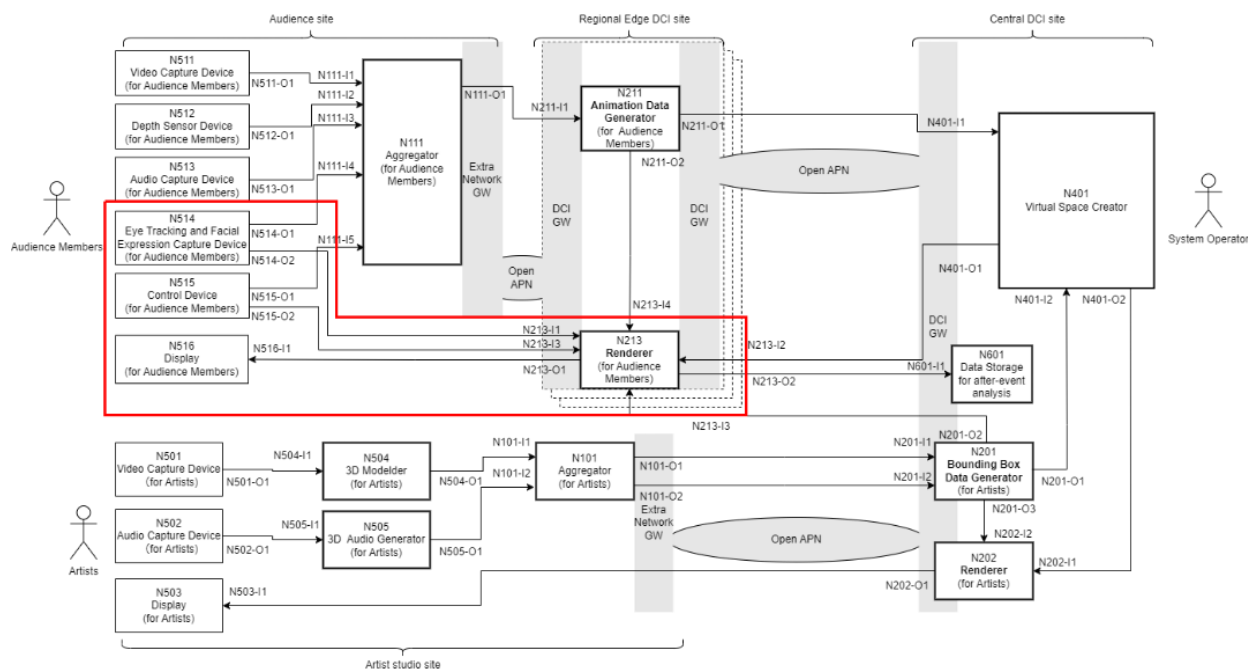

Figure 2.1-1: Overview of PoC-RVD

As one of the most critical parts of the ILM RIM in terms of latency, data volume, computing workloads, and energy consumption, this PoC Reference focuses on the PoC-RVD.

Figure 2.1.1-1 provides an overview of the PoC-RVD in the ILM RIM. PoC-RVD corresponds to the "motion-to-photon latency" of the ILM RIM Document processing flow, consisting of sensor devices, Renderer Node, and Display.

The PoC-RVD is responsible for collecting data from a number of geographically dispersed Audience Member sensor devices, e.g. image sensors, and converting it into the appropriate form, e.g. into Animation data. It also combines it with Avatar Data from the Virtual Space Creator Node, performs Rendering and transmits the rendered video to the Audience Member. The Artist is captured as a volumetric video, which increases the rendering load to generate views for each individual. In the ILM RIM Document, low latency and low power consumption data transfer/processing is realized through the use of high-speed data sharing methods such as RDMA over APN, implemented on Renderer Nodes in Edge DCs.

The aim of this PoC-RVD is to validate the applicability and effectiveness of the solution set for PoC-RVDs and to prove that PoC-RVDs with IOWN GF technology can be a building block to realize the ILM UC with low power consumption.

2.1.2. Selected Features

This section describes the selected features of the PoC-RVD to fulfill the aims of the PoC.

As mentioned in the previous subsection, the aims of this PoC are not to implement complete feature sets and conduct performance testing for prototyping but to examine the applicability of IOWN GF technologies to the target use cases and to prove their effectiveness. Although the scope of this PoC is narrowed, there are still many functional and non-functional features described in the ILM RIM Document [IOWN GF ILM RIM]. Furthermore, it is envisaged that a single Virtual Space can accommodate up to 3,000 Audience Members, with multiple sensor devices per Audience Members. It is therefore recommended the development start with a part of the PoC-RVD with a selected feature set, as a full-scale system may be too large.

The following sections include features that need to be implemented in the PoC and their requirements with references to the corresponding parts of the ILM RIM Document. The following sections also show some notes that may not be described in the ILM RIM Document but should be taken into consideration in the PoC. Then, the latency and scalability requirements for the PoC are discussed in Section 2.1.2.6 and Section 2.1.2.7.

Figure 2.1.2-1 illustrates the PoC-RVD implementation example. The dotted line above indicates the path for the Audience Node to receive input from the user's keyboard and send that data to the Renderer Node with SmartNIC. The dotted line below illustrates the path for transferring data rendered by the Renderer Node's GPU to the Audience Node with SmartNIC.

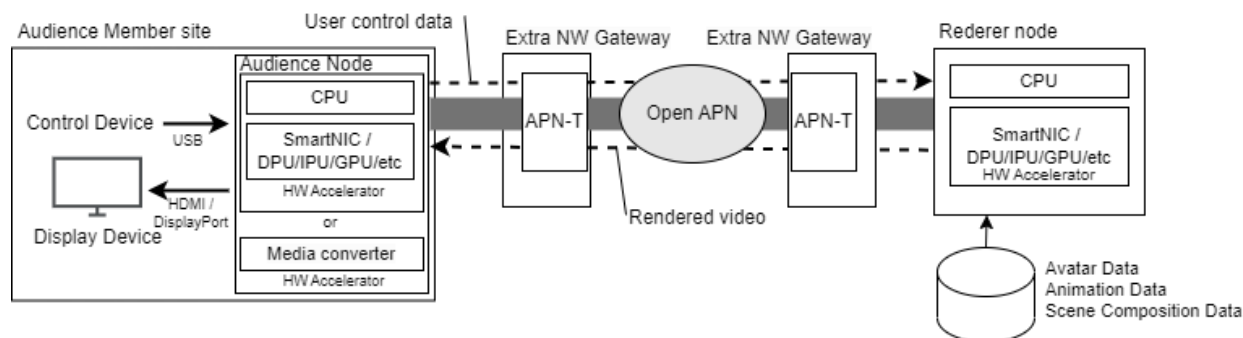

Figure 2.1-2: Implementation Example

2.1.2.1. Device Requirement

2.1.2.1.1. Control Device

- Device Type
 - HMD
 - HMD as a Control Device refers to the built-in sensors of HMD. Most HMDs currently on the market are with built-in 6-axis accelerometer and some external buttons.
 - Keyboard / Mouse
 - The use of HMDs is assumed in the RIM, but if evaluation is difficult due to HMD-specific implementation, Keyboard / Mouse may substitute, since the latency is small.
 - Audience Node
 - The Audience Node consists of a CPU, GPU(s), an Ethernet port, and a USB interface or has an interface converter between the Ethernet port and DisplayPort (or HDMI) or USB interface. The PoC Report should include details of the system configuration.
- Device Properties

- HMD
 - USB interface
 - Polling rate of HMD sensing data: 120Hz or higher
- Keyboard / Mouse
 - USB interface
 - Polling rate: 125Hz or higher
- Note: Although the minimum specifications are presented here for ease of experimentation, it should be stated that the choice of equipment has a significant impact on the motion-to-photon or click-to-photon latency. As stated in Section 2.1.2.6, the target latency is expected to be 10ms, but if the USB polling rate is 120Hz, data transmission takes up to 8.3ms and 4.2ms on average, consuming most of the budget. Therefore, PoC Report should include various parameters, such as the scan rate of the device used.

2.1.2.1.2. Renderer Node

- Functional Features
 - Loads data comprising the 3D scene from storage. 3D scene is Scene Composition Data that contains information about the venue, Avatar Data, Animation Data and Artist 3D Data. Artist can be presented by a point cloud or mesh texture.
 - Perform the rendering based on the movement of Audience Member.
 - Any data format for Animation Data, etc. can be used. The used format details should be described in the PoC Report.
 - Here, rendering is the creation of a viewport for each Audience Member from Artist 3D model, Scene Composition Data, Avatar Data and Animation Data.
 - Regarding the number of Audience Members in one Virtual Space, the PoC can be conducted with less than 3,000 Audience Members so that the latency requirement can be satisfied. The detailed configuration should be reported in the PoC Report.
 - Send the rendered video data to Audience Member site using a fast memory-to-memory data transfer method by HW accelerators such as a SmartNIC or a media converter.

In PoC-RVD, it is not necessary to implement all of the ILM RIM as is, but it is essential to implement the part that sends the data out. Here, a simplified Rendering Node that reads and sends out data is assumed as a minimum requirement. Also, the data size and data format do not have to be the same as described in the ILM RIM Document, but the details should be described in the PoC Report. The PoC Report should also include the equipment used, assuming the use of HW accelerators such as GPUs. Please refer ILM RIM Document for details.

2.1.2.1.3. Display Devices

- Device Type
 - HMD, flat panel display
- Device Properties
 - Refresh rate: 120Hz or higher

2.1.2.2. Network Requirement

2.1.2.2.1. User Control Data from Audience Member site to Renderer Node

- Network Type
 - Network type is not specified but use of Open APN is recommended.

- Communication Distance
 - Communication distance is not specified but the following points should be taken into account.
 - Considering the motion-to-photon latency target, the upper limit is 500 km round-trip, as the transmission speed in optical fiber cable is 5 ms at 1000 km. However, this assumes an edge server and distances should be measured from short to long.
 - Network distance may be simulated using a network latency emulator.
- Communication Protocol
 - Communication protocol is not specified but the following points should be taken into account.
 - Example communication protocols are RTP, HTTP, QUIC, etc.

2.1.2.2.2. Rendered Video from Renderer Node to Audience Member site

- Network Type
 - Network type is not specified but use of Open APN is recommended.
- Communication Distance
 - Communication distance is not specified but the following points should be taken into account.
 - Considering the motion-to-photon latency target, the upper limit is 500 km round-trip, as the transmission speed in optical fiber cable is 5 ms at 1000 km. However, this assumes an edge server and distances should be measured from short to long.
 - Network distance may be simulated using a network latency emulator.
- Communication Protocol
 - Example communication protocols are SDI (Serial Digital Interface), HDMI, DisplayPort, RDMA etc.
 - In case of RDMA, this technology enables the servers to swiftly read and write memory data between each other at high speeds, bypassing time-consuming processing by the operating system or CPU. An example is described in Annex A.
 - It is recommended that the PoC Report include a comparative performance analysis between the protocol such as RDMA and conventional baseband communication protocol stacks (e.g., SDI/HDMI/DisplayPort, etc.

2.1.2.3. System Requirement

2.1.2.3.1. Latency

The target motion-to-photon latency of the ILM UC is expected to be less than 10m sec. The budget for latency is very small, so non-network delays should also be minimized. Please see Section 2.1.4.1 Latency for the detailed definition of motion-to-photon latency.

2.1.2.3.2. Scalability

This PoC Reference does not set any restrictions on the scale of the PoC (e.g. number of Audience Members). However, the implementation strategy and the scale of the PoC should be considered so that the required system resources and system costs of the actual production system can be estimated.

For this reason, the following should be estimated,

1. Number of Audience Members can be supported by one Render Node with a pair of CPU and GPU.
2. Number of times higher performance Render Node with a pair of CPU and GPU are needed to support a certain number of Audience Members.

If a container platform or a virtual machine is used, the detailed configuration should be reported in the PoC Report.

2.1.3. Advanced Optional Features

This section describes the selected features for the PoC-RVD, from the advanced features discussed in the ILM RIM Document.

2.1.3.1. Data Collection via Network and Artist 3D Model Loading

To make the PoC more appealing to the industry, it is encouraged that additional features described in the ILM RIM document are implemented and demonstrated. Examples of such features include:

- Receiving data from Animation Data Generator Node, Virtual Space Creator Node, and Bounding Box Data Generator Node

2.1.3.2. Point to Multi-Point

Because PoC-RVD is a PoC between Renderer Node in edge DC and Audience Node in Audience Member site, the use of access network domain of the Open APN is essential. Demand based flexible allocation of the guaranteed unicast bandwidth resource between edge DC to each Audience Member site, which enables flexible number of Audience Members access per Audience Member site, is also important to prove the scalability and the QoE of the ILM UC (especially for B2B services) while realizing the KPIs such as latency.

Figure 2.1.3.2-1 shows an example of the functional architecture of the Open APN PtMP (Point to Multi-Point) access network and the FDNs (Function-Dedicated Networks) for PoC-RVD between Renderer Node in edge DC and Audience Node in Audience Member site.

Currently four types of path services are defined in Section 2.1 Service Types of the Open APN Functional Architecture Release 2 Document [IOWN Open APN]. Any of the above four types of path services can be chosen, however for the proof of scalability of the service in the PoC-RVD, the use of the PtMP path services as specified in the Section 2.1.2 and 2.1.4 of the document is recommended.

Extra Network FDN Gateway is assumed to have at least one APN Transceiver (APN-T) and one or multiple of local-network-interface port(s) of 10G, 25G or 100Gbps of Ethernet which connect(s) to Audience Node (such as Eye Tracking and Facial Expression Capture Device, Control Device and Display) via Audience Node(s) (such as “PC(s) with DPU and SmartNIC” or “Low Latency Media Converter(s)”). The allocation of dedicated local-network-interface port for each set of the Audience Node(s) and Local Devices for each Audience Member, and dynamic and stable bandwidth-resource allocation for the unicast service over PtMP access path, are assumed.

In terms of flexible bandwidth resource allocation per Audience Member site, any of the four multiplexing technologies (TDM PON, WDM PON, TWDM PON and SCM (Sub-Carrier Multiplexing)) for PtMP, which are defined in F.1 Multiplexing Methods of Annex F [IOWN Open APN], can be chosen. However, note the following important points to realize the PoC-RVD;

1. The range of available guaranteed bandwidth for unicast data transmission over PtMP path
2. Flexible re-allocation of bandwidth-resource for each Audience Member site

Regarding the selection of APN-T, any of the APN-T for the above multiplexing technologies can be chosen. Open XR Optics is an example of APN-T that meets both Section 2.1.2. PtMP Wavelength Path Service and on-demand flexible bandwidth re-allocation by SCM, which is available with Extra Network FDN Gateway Ethernet Switch. Open XR Optics can be hub side APN-T (MP-H) located in edge DC or leaf side APN-T (MP-L) located in Audience Member site in Figure 2.1.3.2-1. Demand based flexible allocation of the bandwidth resource (e.g., 0Gbps, 100Gbps, 200Gbps,...) for each leaf side APN-T (MP-L) by using SCM technology is one of the features of Open XR Optics. The minimum bandwidth re-allocation step for Open XR Optics APN-T (MP-L) is 25Gbps.

PoC Reference: Reference Implementation Model for the Interactive Live Music Entertainment Use Case

Since the Open APN PtMP services is currently not available in the field, it is assumed to use test bench with dummy fiber in this PoC-RVD for PtMP access, and the minimum number of Audience Member site is one (1).

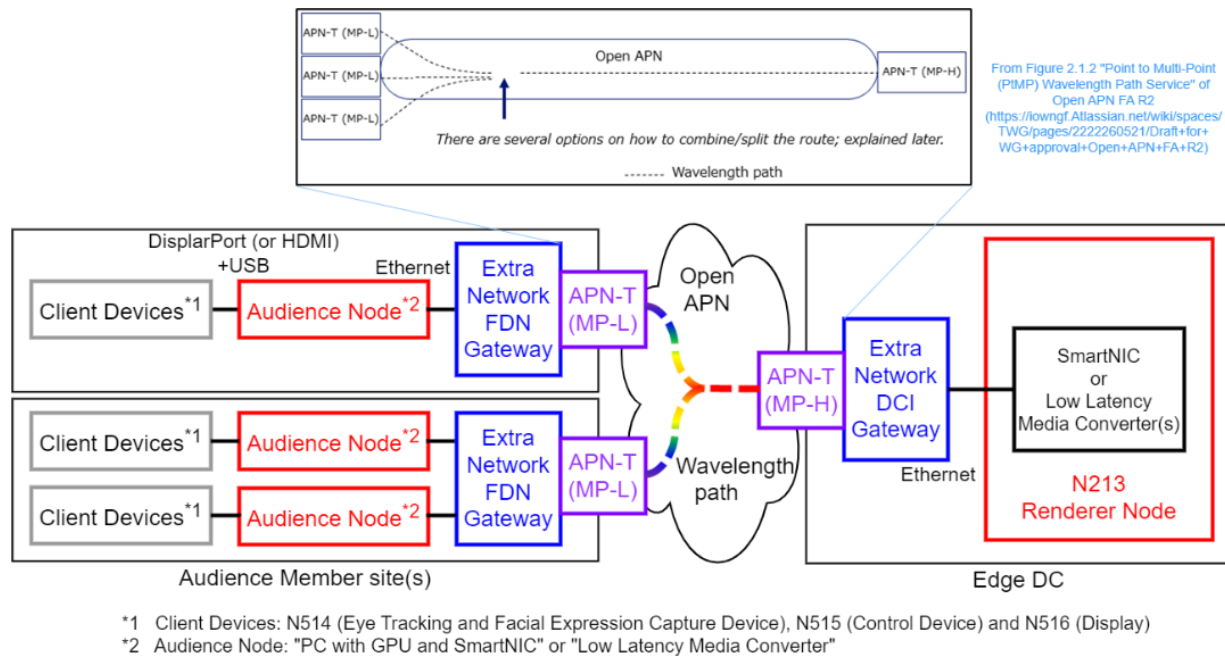

Figure 2.1-3: Example of the Open APN PtMP and FDN Functional Architecture between Renderer Node in Edge DC and Audience Node in Audience Member Site(s)

2.1.3.3. Additional Improvements

One of the objectives of this PoC is to find potential technical improvements toward Release 2 of the ILM RIM Document, therefore additional features to support potential technical solutions can be incorporated, to evaluate their benefits. Examples of such potential technical solutions include:

- Real-time generation of the Animation Data from sensor data
- Real-time streaming of volumetric video for Artists
- Distributed rendering at multiple Renderer Nodes in multiple edge DCs
 - The objects in the 3D scene that are particularly heavy in rendering are processed by a separate rendering server and composited together at the end.
 - Aggregating rendering processes for multiple Audience Members on a Rendering Node to keep high utilization ratio and reducing the total number of the Renderer Nodes. This contributes to the cost-effectiveness.

2.1.3.4. Compression Methods

- The compression mechanism(s) contribute to reducing data traffic volume, energy consumption, and system cost. However, it has a penalty in terms of latency. To balance these two, i.e, to contribute to system cost reduction while meeting ILM UC requirements, lightweight compression mechanism(s) may be applied. Therefore, it is recommended to test such compression mechanism(s) during the PoC.
- The compression mechanism(s) which are used for the delivery of video, audio and/or meta-data over the network should be documented in the PoC Report.

2.1.4. Expected Benchmark

This section identifies the benchmarks that are expected to be evaluated. The KPIs for the benchmark defined in this PoC Reference are latency, system resources and configuration, and energy efficiency. The PoC Report should include the evaluation results in terms of the three KPIs.

2.1.4.1. Latency

Since the goal is not to evaluate HMD devices itself, use of low latency gaming keyboard or mouse is recommended, so as not to rely on the predictive capabilities of the HMD-specific implementation. If an HMD is used the predictive capability should be turned off. This measurement method is called click-to-photon and is as described below;

- Scope
 - Latency
 - from the moment of user input, e.g., the user types a key or clicks a mouse button, or moves his/her head with the HMD
 - to the time when the Display shows the video frame of the scene rendered based on the User Control Data of "user input" above.
 - The PoC Report must include the breakdown of the components comprising the latency, e.g. rendering, network, display and input delay. The display and input delay may be estimated from the device specification. The PoC Report must include a detailed analysis of each latency component and possible mitigation technology to meet the requirement.
- Metrics
 - 0.1 millisecond order
- Measuring Method
 - Details are provided in Annex B. The PoC Report should describe the measurement method in detail.

2.1.4.2. Required System Resources and Configuration

- Scope
 - The overall system resources and configuration for the PoC
- Metrics
 - Describe the environment used for the evaluation
 - Network and system configuration, including devices, servers, and networks
- Measuring Method
 - Provide the system components, such as the number of devices, number of CPUs, memory size, and bandwidth.

2.1.4.3. Energy Efficiency

- Scope
 - The total energy consumption of the system resources for the PoC
 - The energy consumption of the Renderer Node should be measured.
 - The measurement of the energy consumption of network equipment is optional since they might be emulated.
 - The energy consumption of the Audience Node should be measured.

- Metrics
 - Total energy consumption (Wh)
 - Energy consumption per Audience Member
- Measuring Method
 - Measuring method should be documented in the PoC Reports

2.1.4.4. Network Resource

For evaluating the quality of video transmission, the following information about network resource allocation should be measured. This information can be used to confirm (1) the flexibility of bandwidth allocation per Audience Member site and (2) the affectability of statistical multiplexing at the Extra Network FDN Gateways.

- Scope
 - The network bandwidth resource allocation and consumption, QoS and latency in Access Network between edge DC and physical venue for the PoC
- Metrics
 - The metrics for network resource are as follows (for each direction)
 - Bitrate allocation and consumption of total traffic via APN at the Extra Network Gateways
 - Bitrate for each Audience Node
 - Packet loss rate between the Extra Network Gateways (and between the Renderer Node and the Audience Node (optional))
 - Packet delay between the Extra Network Gateways (and between the Renderer Node and the Audience Node (optional))
- Measuring Method
 - Measuring method should be documented in the PoC Reports

2.1.5. Other Considerations

The PoC Reports should include considerations regarding the following items:

- Provide qualitative and quantitative analysis by comparing IOWN GF technologies with existing technologies.

2.2. PoC for Scalable Architecture for Renderer and Virtual Space Management (PoC-SAR)

This section describes a PoC scenario and its requirements to the applicability of building a Scalable Architecture for Renderer and Virtual Space management (PoC-SAR). To let thousands of audiences join, enjoy, and interact together in a virtual event, a new architecture supported by the IOWN GF technologies needs to be developed. A system built in such a way is expected to be able to project the movements and actions of hundreds or thousands of other participants in the field of view of each Audience Member with the lowest possible latency while reducing the rendering workload on the GPU.

The overview of PoC-SAR is provided in Section 2.2.1. Selected features for the PoC are discussed in Section 2.2.2. The PoC Reports need to cover all the features in Section 2.2.2 to be recognized as an IOWN Global Forum PoC Report. Then, the advanced optional features of PoC are explained in Section 2.2.3, which are not mandated. Finally, the expected benchmark of the PoC and other considerations are described in Section 2.2.4 and Section 2.2.5, respectively.

2.2.1. Overview

The scope of the PoC-SAR is illustrated below.

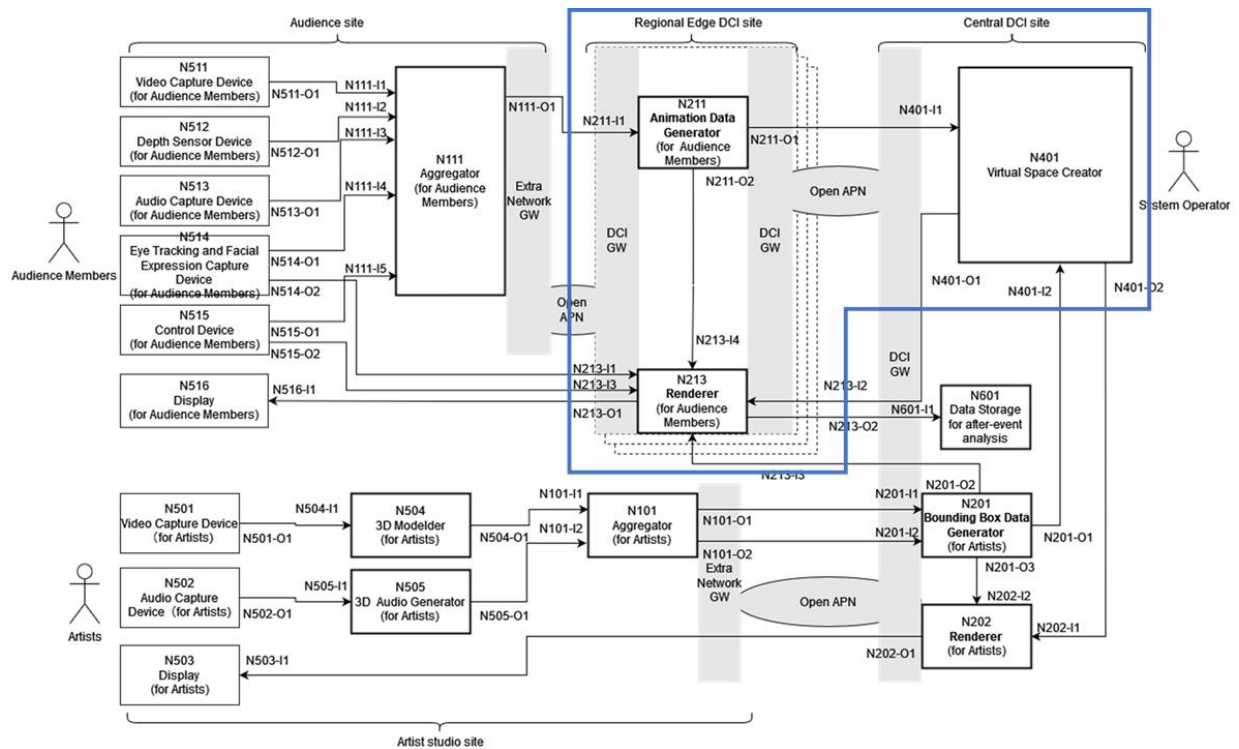

Figure 2.2-1: Overview of PoC-SAR

As relevant ideas were discussed in the ILM RIM Document [ILM RIM], it is difficult to achieve scalability, real-time performance, and cost-effectiveness around Rendering and Virtual Space management at the same time. In this regard, the PoC-SAR is designed to further break down such a possible architecture hypothesis and test it to know whether the ILM UC requirements can be met or not.

As shown in Figure 2.2.1-1, the PoC-SAR is designed to cover the component N211, N213, N401, and their interactions, because a sequence of collecting data from thousands of Audience Members, building a virtual space, and rendering for each Audience Members considered to be the core of the ILM use cases.

To conduct the PoC-SAR, it is required to make a hypothesis on the physical configuration of these components. From this point of view, as a prerequisite for PoC-SAR execution, a physical configuration shown in Figure 2.2.1-2 is determined, which is considered an integrated model of the ideas explained in Annexes H, I, J of the ILM RIM Document [ILM RIM]. It should be noted that there are other options in determining the physical configuration of the components. Please refer to Annex C for some examples of such other options and a comparison among those options.

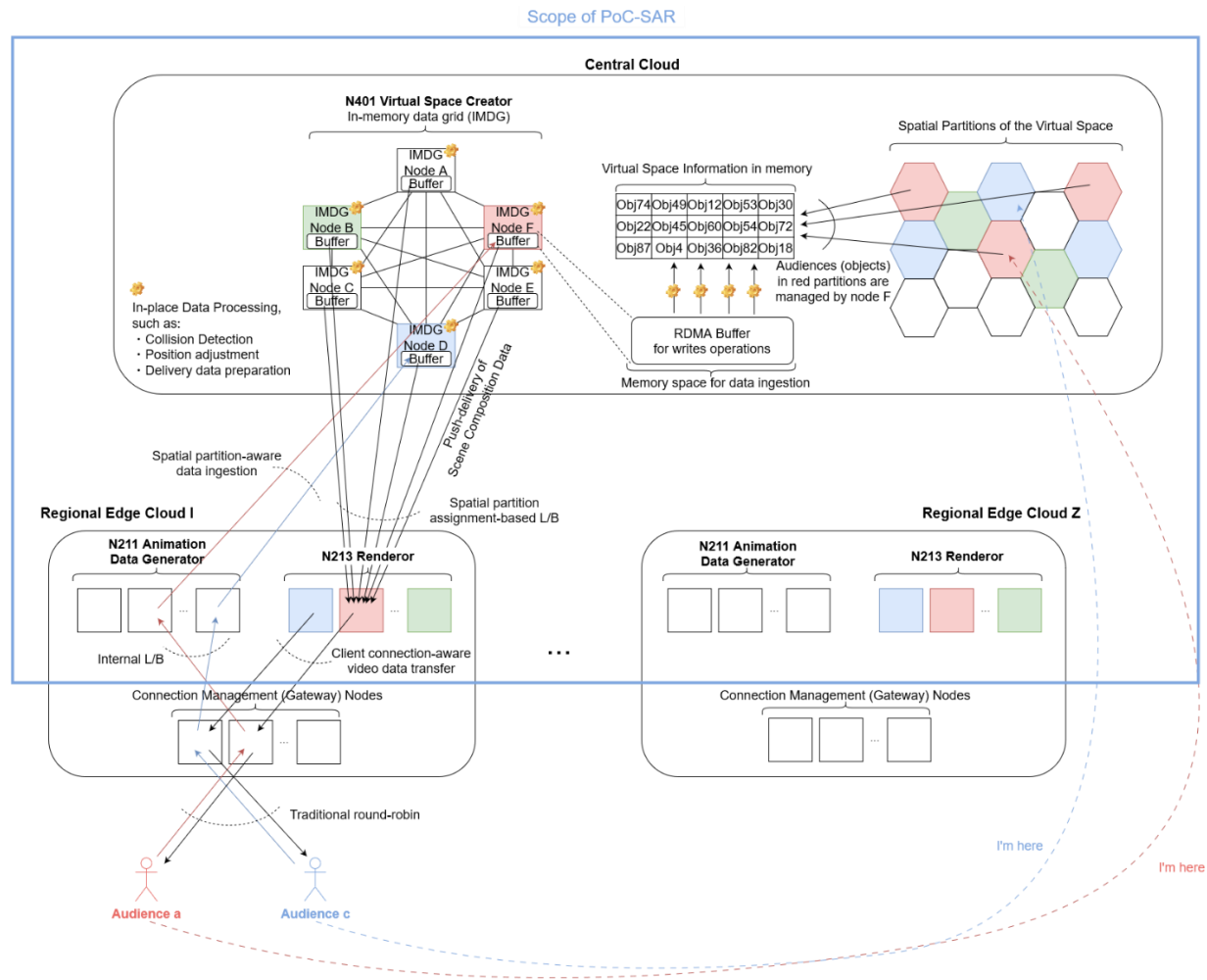

Figure 2.2-2: Assumed Physical Configuration of PoC-SAR

The roles and responsibilities of included components N401, N211, and N213 are as follows;

- N401 Virtual Space Creator
 - In-Memory Data Grid (IMDG) is used as a foundation for better performance and scalability. As there is no need to preserve the data change for a long period, it is just sufficient to temporarily store data in memory. Each node in the IMDG is assigned to a set of spatial partitions of the virtual space. If the number of partitions assigned to each node is big enough and the same overlap prevention law is applied as in real space, Audience Data is roughly equally distributed among nodes no matter how big the virtual event space is and how many Audience Members participate in the event. To streamline data ingestion to the IMDG, an RDMA-enabled buffer area is exposed to the remote N211 Animation Data Generator component, i.e., data ingestion nodes. As it is desired to let the remote data ingestion nodes ingest data through RDMA-write in parallel, a connection layer needs to be designed to automatically offset the memory address whenever it receives new data so that any data collision can be avoided. Audience Data ingested in the buffer area is adjusted to avoid collisions with other Audience Members and used to produce different resolution data as a foundation to reduce the rendering load, which is described later, and then stored in the memory area for data transfer. In the memory area for data transfer, data is version-controlled. This means that data that is still under transfer to the N213 Renderer component will be kept intact. New data about the same Audience Member will be updated in a separate memory address with a

new version number. Once the data transfer is completed, then the data is deleted from the IMDG. When transferring data from the N401 Virtual Space Creator component to the N213 renderer component, RDMA-write will be used. This is because data consistency management is easier than letting the N213 component do RDMA-read. And, for this purpose, the N401 component must always know the configuration of the N213 component.

- N211 Animation Data Generator
 - Multiple nodes will be used to construct the N211 Animation Data Generator component. To equally distribute the workload and data among these nodes, the data sent from the Audience Member's devices is primarily received by one of the connection management nodes, which is basically fixed per Audience Member during the event, and distributed evenly to these nodes through the load balancer. The Animation Data Generator component shall be aware of the IMDG configuration so that data can be directly ingested to the right IMDG node through RDMA-write.
- N213 Renderer
 - Multiple GPU nodes will be used to construct the N213 Renderer component. To distribute the rendering workload among nodes, each rendering node is assigned to one or a few spatial partitions and is responsible for generating field-of-view images for Audience Members located within the assigned partition(s). In addition, to reduce the rendering workload, the resolution of Audience Members in distant partitions will be lowered, i.e., the level-of-detail controls need to be applied. Such resolution adjustment might be conducted with the support of the N401 component that performs RDMA-write.

In addition to the above system design, to conduct PoC, it is necessary to decide on its scale. One of the purposes of the PoC-SAR is to verify scalability, so it is necessary to set up an environment with multiple nodes. As shown in Figure 2.2.1-3, at least 3 nodes, or more nodes if possible, need to be configured to build a test environment of the N401 Virtual Space Creator component and N211 Animation Data Generator component. For N213 components, as each node can render the field of view images independently of each other, only one node is required to measure the latency associated with the rendering process. However, as data transfer workloads at the Virtual Space management component need to be reproduced, the dummy N213 nodes need to be put in to receive the data from N401 nodes.

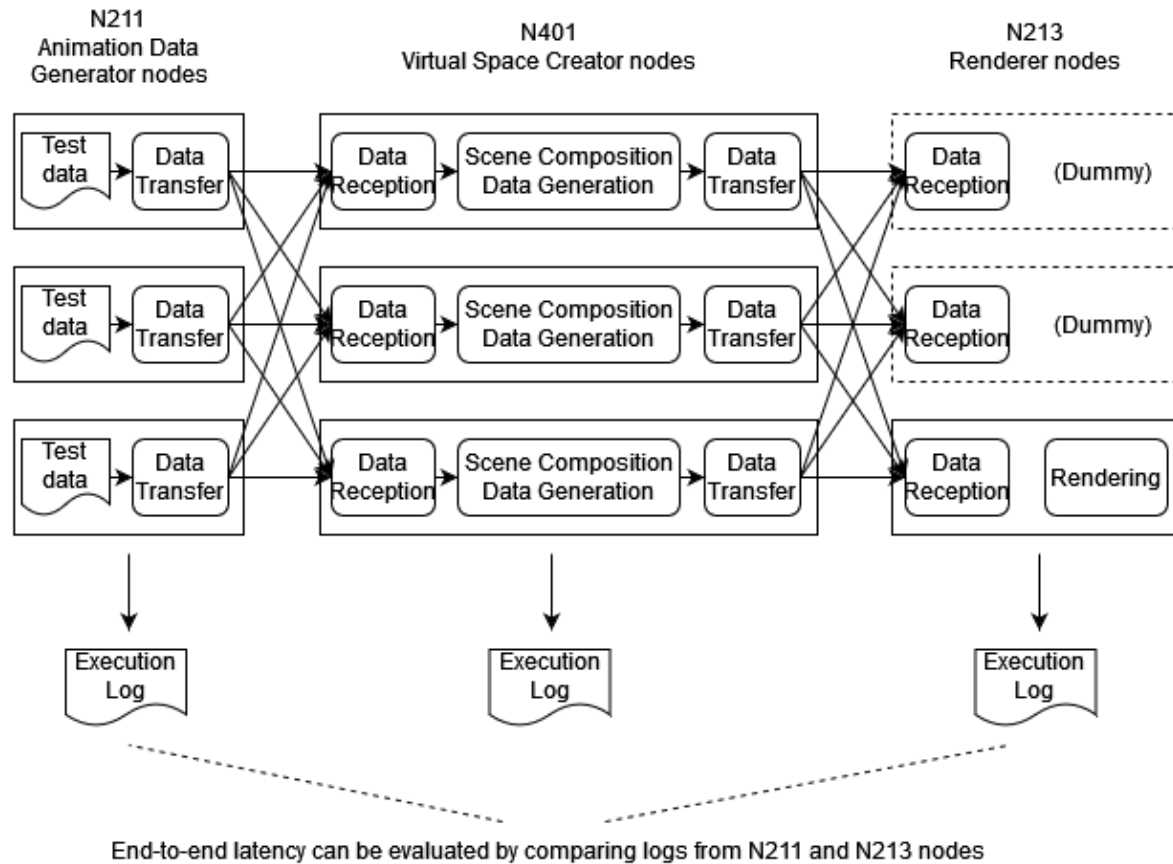

Figure 2.2-3: Assumed Physical Configuration of N211, N213, and N401 Nodes in PoC-SAR

As a whole, the aim of this PoC-SAR is to validate the applicability and effectiveness of the above architecture to build the scalable, real-time, and cost-effective Rendering and Virtual Space Management, that are inevitable to realize the ILM UC.

2.2.2. Selected Features

This subsection describes the selected features that need to be implemented for three components explained in Section 2.2.1 and tested during the PoC-SAR.

2.2.2.1. Selected Features for N401 Virtual Space Creator

The selected features for N401 Virtual Space Creator are as follows;

- Open APN Usage
 - The PoC environment should be configured assuming that the connections between the regional edge clouds and the central cloud, between the regional edge clouds, and between the nodes within each regional edge cloud are connected through the Open APN. For flexibility, electrical-to-optical conversion can be assumed at regional edge cloud connection points, but it should be minimized.
- RDMA-enabled Buffer
 - To streamline data ingestion, an RDMA-enabled buffer is embedded in all Virtual Space Creator nodes and exposed to the Animation Data Generator nodes. The Animation Data Generator nodes ingest animation data to adequate Virtual Space Creator node through RDMA-write based on the

location of the Audience Member's avatar in the Virtual Space.

It should be noted that multiple Animation Generator nodes send raw Animation Data to this buffer at the same time. To avoid data collisions, it is necessary to introduce a mechanism on the host side to offset the RDMA memory address every time receiving a RDMA-write packet, or to allocate separate RDMA-enabled buffer space for each Animation Data Generator node.

- Version Control for Data
 - A series of processes of receiving raw Animation Data, generating and sending the Scene Composition Data (and the Avatar Data if it is generated in the Virtual Space Creator node as an option) is always executed continuously for each Audience Member. So, for example, new raw Animation Data may be received before the generated data has been sent out, overwriting the generated data during the data transfer. To avoid such overwrites, raw Animation Data and Scene Composition Data in the N401 Virtual Space Creator nodes should be version-controlled. Once the data has been sent to all Renderer nodes, the generated data for that version is deleted. It should be noted that there would be a couple of options available for implementing version control functionality. Below are two such examples;
 - Generic memory management mechanism where all Audience Member Data is managed together: In this case, it may be necessary to perform garbage collection to free up the memory space occupied by the deleted data. Garbage collection is a factor that destabilizes performance, so it must be considered as well.
 - Per-Audience Member memory space allocation: In this case, a certain amount of memory space that can store a few versions of data is allocated to each Audience Member. The generated data is written to the allocated memory space in order. For safety, it is also possible to provide a locking mechanism to prevent further writes to this memory space if there is data still pending in the data transfer. Also, please consider that this method requires more memory.
- Data Transfer
 - At least the Animation Data included in the Scene Composition Data is transferred to the Renderer nodes by Virtual Space Creator nodes through RDMA-write. When transferring the data to Renderer nodes, Virtual Space Creator nodes consider the spatial partition assignment to the Renderer node.

2.2.2.2. Selected Features for N211 Animation Data Generator

The selected features for the N211 Animation Data Generator are as follows:

- Virtual Space Creator Configuration Information Management
 - To perform pinpoint data transfer from the Animation Data Generator node to the Virtual Space Creator node, the allocation information of the spatial partition to the Virtual Space Creator node is managed in each Animation Data Generator node. Ideally, Virtual Space Creator should be able to scale dynamically online, but this is not a mandatory requirement for this PoC. (Please see Section 2.2.3 Advanced Optional Features).
- Data Transfer
 - The Animation Data Generator transfers the raw Animation Data to the appropriate Virtual Space Creator node through RDMA-write. Data transferred by RDMA-write is written to the RDMA-enabled buffer of the Virtual Space Creator node.

In a production system, the Animation Data Generation nodes contain processes of generating animation data based on depth sensor data and audio data. However, these processes are outside the scope of this PoC. In other words, PoC can be done using pre-generated animation data.

2.2.2.3. Selected Features for N213 Renderer

The selected features for N213 Renderer are as follows:

- **RDMA-enabled Buffer**
To streamline data reception, an RDMA-enabled buffer is embedded in all Renderer nodes and exposed to the Virtual Space Creator nodes. The Virtual Space Creator nodes transfer the generated animation data to render nodes with an appropriate resolution based on the location of the Audience Member avatar in the virtual space.
It should be noted that multiple Virtual Space Creator nodes send raw animation data to this buffer at the same time. To avoid data collisions, it is necessary to introduce a mechanism on the host side to offset the RDMA memory address every time receiving a RDMA-write packet, or to allocate separate RDMA-enabled buffer space for each Animation Data Generator node. Of course, the implementation design of this feature can be determined.

As a whole, the aim of this PoC-SAR is to validate the applicability and effectiveness of the above architecture to build the scalable, real-time, and cost-effective Rendering and Virtual Space Management, that are inevitable to realize the IOWN Global Forum's ILM use case.

2.2.3. Advanced Optional Features

This subsection describes the advanced optional features of the PoC-SAR. These features are not mandatory requirements but are valuable to further accelerate the performance and/or to well prepare for production. Therefore, they should be tested and included in the PoC Report.

2.2.3.1. N401 Virtual Space Creator

The advanced optional features for N401 Virtual Space Creator are as follows:

- **Collision Detection and Position Adjustment**
 - This feature is to detect collisions between Audience Members and/or between Audience Members and static obstacles, and then adjust their position.
It should be noted that to detect collisions occurring near the boundaries of spatial partitions, data needs to be checked across multiple nodes. To implement this feature, presumably, a master node is determined for each boundary of the spatial partition, the data of the Audience Member near the boundary is transferred to the master node, collision detection is performed there, and if the position adjustment is conducted, it is notified to the slave node.
- **LoD-controlled Avatar Data Generation**
 - The Virtual Space Creator nodes may be configured to generate LoD-controlled Avatar Data from the received animation data. This is because there are two possible places to generate Avatar Data; one is the renderer node, and the other is the Virtual Space Creator node. Each of these two options has advantages and disadvantages. The former requires multiple GPU nodes to generate exactly the same Avatar Data consuming more compute resources. The latter requires more data transfer but is computationally efficient as the Avatar Data only needs to be generated once by the Virtual Space Creator nodes. To build a better system, it is necessary to evaluate the data transfer cost and the Avatar Data generation cost in both patterns. If this option is chosen, only the Avatar Data at the appropriate resolution is transferred to the Renderer node by considering the distance between the Audience Member to be visualized and the viewpoint of the rendering in the Virtual Space.
- **Multicasting**

- This feature is to send the Scene Composition Data (and the Avatar Data if it is generated in the Virtual Space Creator node as an option) to the Renderer nodes through multicast. Multicast is a good option because the same Avatar Data needs to be transferred to multiple Renderer nodes.
- Inter-node RDMA Communication
 - This feature is for speeding up the inter-node communications for the above collision detection process with RDMA.
- Dynamic Scaling of the Virtual Space Creator Nodes (IMDG)
 - In the actual service, it is expected that the number of participants will increase or decrease depending on the time. Therefore, the system should be designed to scale dynamically, and Virtual Space Creator is the most difficult one to achieve such scalability.
So, this feature is to provide dynamic scalability in the Virtual Space Creator nodes. The spatial partitions would be re-assigned to a certain node by using the consistent hash algorithm during the scaling operation, and subsequent data ingestion is controlled based on this new assignment. Old allocation information is also considered for a while to complete in-flight data.
- Scaling of CPU and Memory Resource Allocation at Virtual Space Creator Node (IMDG)
 - This feature enables flexible allocation of resources to each node, which is very important to accommodate various service scenarios.
For example, the frame rate of the field-of-view images, the size of the virtual venue and the density of people in it, etc. will vary greatly from service to service. Therefore, the number of CPU cores and amount of memory required for each node should be largely configurable. However, since traditional VM and container environments could only share resources within the physical host, such configuration is not very large, and memory allocation per vCPU is typically around 2-8 GB in today's cloud.
In order to realize various digital services like interactive live music, a more flexible infrastructure needs to be built. It may allow an allocation of 16 or 32GB per vCPU, or a node with 512 or 1024 cores. The method for realizing such an infrastructure is to use technology such as CXL to connect multiple physical hosts to construct a big host, and then use software mechanisms such as software-defined memory to allocate resources to each logical node flexibly.
- Audio Data Mixing
 - The size of the audio data is not small, as there would be many Audience Members and many channels per Audience Member. From that point of view, this feature mixes the audio data per location in the virtual space to reduce the output size of the audio data. Regarding the unit of mixing location, a somewhat finer version of the spatial partitions would be used.

2.2.3.2. N211 Animation Data Generator

The advanced optional features for N211 Animation Data Generator are as follows:

- Depth Sensor Data Conversion
 - This feature is to generate animation data based on depth sensor data. This is a feature that will likely be needed in a production service, and it's worth having that workload measured in the PoC.
- Data Ingestion from outside
 - As shown in Figure 5, the above depth sensor data will be sent from the connection management (gateway) nodes in the production service. This function is for such data reception. Also, RDMA may be applied in the communication between the connection management nodes and the Animation Data Generator nodes.
- Depth Sensor Data Conversion

- This feature is to generate animation data based on depth sensor data. This is a feature that will likely be needed in a production service, and it's worth having that workload measured in the PoC.
- Data Ingestion from outside
 - As shown in Figure 5, the above depth sensor data will be sent from the connection management (gateway) nodes in the production service. This function is for such data reception. Also, RDMA may be applied in communication between the connection management nodes and the Animation Data Generator nodes.
- Dynamic Scaling
 - As event attendance increases and decreases over time, the Animation Data Generator nodes will also need to scale accordingly. this feature is for dynamically increasing or decreasing the number of the Animation Data Generator nodes online.

2.2.3.3. N213 Renderer

The advanced optional features for N213 Renderer are as follows:

- Client Connection Awareness
 - As shown in Figure 2.2.1-2, a connection management (gateway) node will be used to stabilize client connections and seamlessly deliver video data, and when a client logs on to the service, it will be configured to connect to one connection management node in a classic way such as the round-robin. Assuming this, the Renderer node must know the assignment of each client to the connection management node and forward the field-of-view image data to connection management nodes accordingly, and this is exactly what this feature is for. Also, RDMA may be applied in communication between the Renderer nodes and the connection management nodes.
- Client Connection Awareness
 - As shown in Figure 2.2.1-2, a connection management (gateway) node will be used to stabilize client connections and seamlessly deliver video data, and when a client logs on to the service, it will be configured to connect to one connection management node in a classic way like a round robin. Assuming this, the Renderer node must know the assignment of each client to the connection management node and forward the field-of-view image data to connection management nodes accordingly, and this is exactly what this feature is for. Also, RDMA may be applied in communication between the Renderer nodes and the connection management nodes.
- Dynamic Scaling
 - As event attendance increases and decreases over time, the Renderer nodes that may use GPUs will also need to scale accordingly. Therefore, it is necessary to consider whether video data can be provided seamlessly when performing such operations. So, this feature is for dynamically increasing or decreasing the number of Renderer nodes and changing their assignments to spatial partitions in parallel online.
- Rendering
 - The Renderer nodes render the field-of-view images for the Audience Members that are located in the assigned spatial partitions based on the received animation data.

2.2.4. Expected Benchmark

This section identifies the benchmarks that are expected to be evaluated. The KPIs for the benchmark defined in this PoC Reference are latency, scalability, and data processing efficiency. The PoC Report should include these KPI measurements to be recognized as an IOWN GF PoC Report.

2.2.4.1. Latency

As described in the RIM for the ILM RIM Document [ILM RIM], the goal is to visualize the last movement of other Audience Members within a 70 ms delay. Assuming 1) a 5 ms total latency for sending and receiving data between the client and the regional edge cloud, 2) 5 ms data visualization latency including the delay caused for refresh rate at each client device (assuming 200 Hz head-mount display), and 3) 10 ms data intermediation latency at the connection management layer, the end-to-end latency within the PoC scope would need to be less than 50 ms to achieve this goal. This PoC is to confirm whether such latency can be achieved.

- Scope
 - Total latency of the following steps;
 - N211 to send data to N401
 - (Optional) N401 to generate several different resolution levels of LoD-controlled Avatar Data for each frame of the animation data sent from N211
 - N401 to transfer at least the Animation Data included in the Scene Composition Data to N213
 - (Optional) N213 to render a field-of-view image based on data originally sent from N211
- Metrics
 - 0.1 millisecond order
- Measuring Method
 - After synchronizing the clocks of the N211 and N213 nodes (or co-locating them in the same server), record the execution time of the relevant processes in the log.

2.2.4.2. Scalability

As described in the RIM for the ILM RIM Document (2.5), the goal is to accommodate 3,000 people together in the same virtual space. To achieve this goal, the system needs to scale well. This PoC is to confirm whether such scalability can be achieved for the N401 node.

- Scope
 - Scalability of N401
 - The number of N401 nodes should be varied during the PoC.
 - The number of other nodes can be fixed, i.e., the PoC environment can be configured with three N211 nodes, one proper N213 node, and two dummy N213 nodes.
- Metrics
 - the number of Audience Members that can be supported.
- Measuring Method
 - Comparing the performance of the following three configurations:
 - Configuration with one N401 node - all spatial partitions are assigned to the same N401 node.
 - Configuration with two N401 nodes - half of the spatial partitions are assigned to each N401 node.
 - Configuration with three N401 nodes - one-third of spatial partitions is assigned to each N401 node.

2.2.4.3. Data Processing Efficiency

- Scope
 - The data processing efficiency of the system for each configuration with the different number of N401 nodes
- Metrics
 - The number of Audience Members per N401 CPU cores
 - CPU time for data transfers, data processing, garbage collection, and other kernel-level operations
 - Energy consumption (Wh) per Audience Member at each of N401, N211, and N213 nodes
- Measuring Method
 - At a minimum, capture various logs on the host and evaluate them. If possible, it is recommended to use a hardware-based power analyzer.

2.2.5. Other Considerations

The PoC Reports should include considerations regarding the following items;

- Provide qualitative and quantitative analysis of IOWN GF technologies by comparing IOWN GF technologies with existing technologies.
- Provide qualitative analysis of the IOWN GF implementation model described in Section 2.2.1. For this purpose, it can be compared with other implementation models described in Annex C.

3. Summary

This document defines the scope of the PoCs which includes critical parts of the ILM RIM, which are PoC-RVD for Rendering and Video Delivery to Audience Members and PoC-SAR for Scalable Architecture for Renderer and Virtual Space management. In each PoC scope, selected features, advanced optional features and expected benchmarks are explained. In the benchmarks, the KPIs are defined, such as latency, system resources and configuration, throughput, and energy efficiency.

IOWN GF is looking forward to receiving PoC Reports for this PoC Reference. Information provided in the PoC Reports will be used to guide the further development of the IOWN GF AIC Interactive Live Music Reference Implementation Model and related specifications of IOWN GF technologies.

4. References

[ILM RIM]	Reference Implementation Model (RIM) for the Interactive Live Music Entertainment Use Case https://iowngf.org/wp-content/uploads/formidable/21/IOWN-GF-TS-RIMforInteractiveLiveMusicUseCase-1.0.pdf
[IOWN Open APN]	IOWN Global Forum, "Open All-Photonic Network Functional Architecture," 2022.
[A. Ishihara 2023]	A. Ishihara et al., "Integrating Both Parallax and Latency Compensation into Video See-through Head-mounted Display," in IEEE Transactions on Visualization and Computer Graphics, vol. 29, no. 5, pp. 2826-2836, May 2023, doi: 10.1109/TVCG.2023.3247460. [https://ieeexplore.ieee.org/document/10054094] (https://ieeexplore.ieee.org/document/10054094)

5. Abbreviations

0-9

3D, Three Dimensional

B

bps, bits per second

C

CG, Computer Graphics

D

DMA-BUF interface, Direct Memory Access Buffer interface

DC, Data Center

DCI, Data-Centric Infrastructure

DPD, Data Pipeline Diagram

DPU, Data Processing Unit

F

fps, frames per second

H

HMD, Head-Mounted Display

I

ILM UC, Interactive Live Music Use Case

ILM RIM, Reference Implementation Model of the Interactive Live Music Use Case

IPU, Infrastructure Processing Unit

R

RDMA, Remote Direct Memory Access

ROI, Region Of Interest

RTP, Real-time Transport Protocol

S

SDI, Serial Digital Interface

ST2110, SMPTE ST 2110 Professional Media Over Managed IP Networks

T

TCP, Transmission Control Protocol

V

VM, Virtual Machine

6. Terms and Definitions

Reference Case	Detailed description of the use case with specific conditions for determining functional and non-functional requirements, output/input data flow, system size, and parameters in order to make it accurate to evaluate implementation models by measuring selected metrics in the specific conditions.
Virtual Space	Virtual Space is a virtual live music venue. Audience Members can move freely around the live music venue, and the images seen by each participant are individually generated by rendering from each viewpoint. This is conceptual, and the data is represented by separately defined Scene Composition data and visualized by the rendering process in the renderer.
Interactive Music Service	The overall service on the network side for the Use Case.
Audience Member	Person who participates from their homes or karaoke rooms.
Scene Composition Data	<p>Output data from the Virtual Space Creator. It is some part of the elements necessary to construct Virtual Space, which is visualized by the Renderer. The elements of Scene Composition data are as follows;</p> <p>Artists' Bounding Box data (includes determined position and direction)</p> <p>Audience Members' Animation data (includes determined position and direction)</p> <p>Concert Hall component such as 3D model of stage, seats, light position, speaker position, etc.</p> <p>3D audio data for Virtual Space</p> <p>CG effects including lighting and ROI (Region of Interest) Information and provide recommended view port for Audience Member</p> <p>They are expressed in a scene description language and contains both static and time-varying dynamic information. In the 3D scene generation phase, the 3D models are not necessarily required, but only the position and motion information (Bounding Box data and Animation data: time-varying dynamic information) of the 3D models can be used to construct the 3D scene. In the DPD, multiple inputs arrive at the Renderer. Some of the static information can be sent to the Renderer in advance, before going live. They are then integrated before being used for rendering.</p>
SmartNIC	A programmable accelerator that makes data center networking, security and storage efficient and flexible.
Avatar Data	3D model data
Animation Data	Time series data of position and direction of joints to move the Avatar data. The Animation data will be sent to the system in real-time during the live event to move the 3D model, Avatar data. This Animation data includes not only body movements but also facial expressions and eye movements.
LOD	LOD stands for "Level of Detail" and means "degree of detail. It is a method of reducing the computational load of a scene by controlling the number of polygons in the model according to the distance from the camera.
RVD	Rendering and Video Delivery
Low Latency Media Converter	Low Latency Media Converter is a type of protocol and media converter device which converts dedicated interface such as DisplayPort (or HDMI) and USB to Ethernet(IP/UDP/RTP) and vice versa. It can be PC based product or dedicated hardware device, however the low latency feature is essential, because non-negligible amount of the Motion-to-Photon or Click-to-Photon latency can be occurred in the Audience Node(s). It can be a device with or without codec function, however the codec should be open standard based.

PoC Reference: Reference Implementation Model for the Interactive Live Music Entertainment Use Case

Open XR Optics	<p>Open XR Optics is a technology defined by Open XR Forum (https://www.openxrforum.org/). With the combination of Extra Network FDN Gateway which is defined in the Open APN Functional Architecture Document Release 1, Open XR Optics is one of the technology which can provide the “Point to Multi-Point (PtMP) Wavelength Path Service” which is defined in section 2.1.2. of the Open APN Functional Architecture Document Release 2 candidate. [APN FA R2] 2. Services of Open APN. Open XR Optics can also support SCM (Sub-Carrier Multiplexing) in the 4th item of “F.1. Multiplexing method” of “Annex F. Point-to-multipoint technique” of the above.</p>
----------------	--

Annex.A. Implementation Examples for PoC-RVD

This annex describes an example server-client architecture and implementation using SmartNICs or Low Latency Media Converter.

PoC-RVD in brief, assuming the ILM UC,

1. Loads data comprising the 3D scene from storage.
2. Perform the rendering based on the information from the Audience Member.
3. Send the rendered video data to Audience Member directly from GPU memory via SmartNIC or Low Latency Media Converter using a direct memory-to-memory data transfer method, such as RDMA or realtime transfer protocol such as RTP.

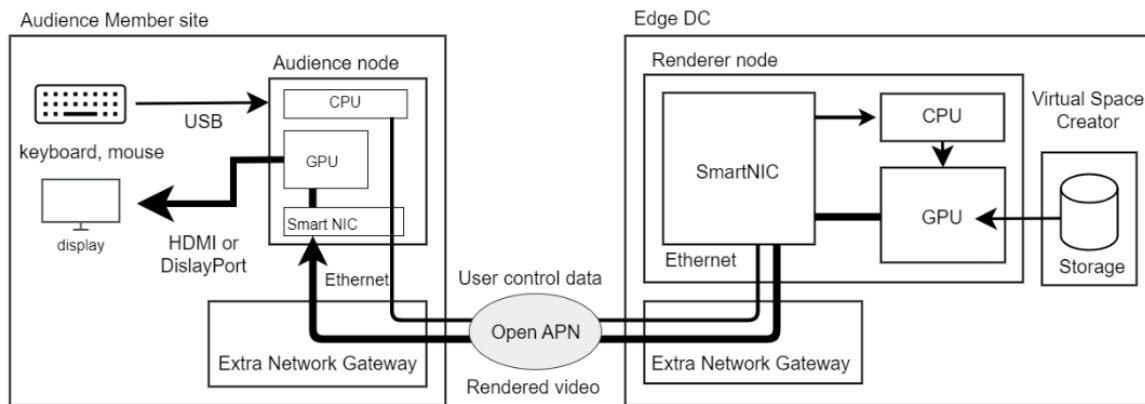

Figure A-1: An Implementation Example with RDMA

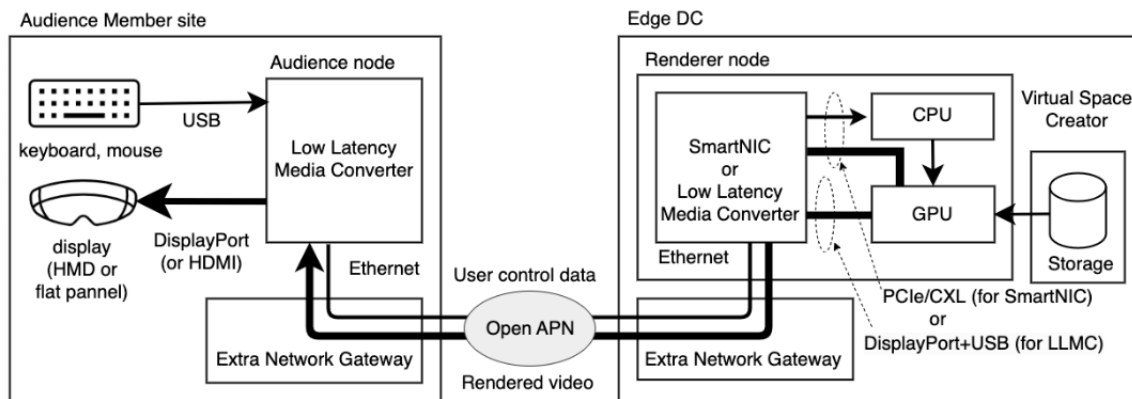

Figure A-2: Implementation Example with RTP

Annex.B. How to Measure the Motion-to-Photon Latency

This Annex describes how to measure the motion-to-photon latency for HMD and click-to-photon latency, using keyboard or mouse as control device, for a flat panel display.

B.1 Motion-to-Photon

An IEEE Paper [A. Ishihara 2023] explains an example measurement method using an HMD. A light bulb placed 1m from the HMD is shot by two synchronized cameras, one camera directly shooting the light bulb and the other shooting through the HMD. By analyzing the difference between the two shot images, the latency can be measured.

Note: In the case of commercial VR, the measurement can only be done including the Time Warp function, so it is not possible to measure the exact network and computing node processing latency values.

B.2 Click-to-Photon

If the Display Device is a flat panel display rather than an HMD, the following measurement method is valid. This method enables the measurement of the pure network latency from which the effect of latency reduction function implemented in the HMD are excluded.

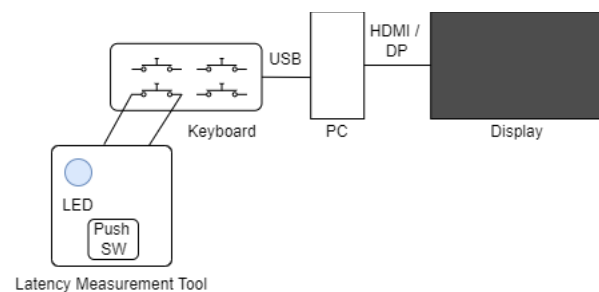

Figure B.2-1: Overview of the Latency Measurement System

Note: This figure is just for explanation of the measurement. It should be cloud rendering for PoC.

B.2.1 Configuration

- High frame rate camera
- PC and display
- External keyboard or mouse
 - USB Polling rate is typically 125Hz, which corresponds to maximum 8ms latency. Therefore it is preferable to use a low latency gaming keyboard.
 - Some gaming keyboards are available with 8,000 Hz, which is 1/8000 sec and has negligible latency.
- Latency Measurement Tool
 - Latency Measurement Tool is a tool that, when the push-switch is pressed, causes the LED to light up and shorts the key on the keyboard at the same time.

Note: It is difficult to judge the timing of keyboard keys and mouse clicks from the video, so LEDs are illuminated to enable objective judgments.

B.2.2 Measurement Method

- Connect the Latency Measurement Tool to your target PC and keyboard to control.
- Launch an application for the purpose of evaluation that changes the screen in some way when it receives a key input.
 - Prepare two images; one with a certain region black, and another with the same region white. Use data values $(R,G,B)=(0,0,0)$ and $(R,G,B)=(255,255,255)$ respectively for black and white color (for 8-bit image). The server changes between the prepared images (from black to white) upon reception of user input.
 - The region should be placed in the vertically middle of the screen because the image gradually changes from top to bottom.
- High Frame Camera
 - Start video recording with a high frame rate camera.
 - When the button on the Latency measurement tool is pressed, the LED lights up. At the same time, a key on the keyboard is also pressed. The light emitted by the LED makes it possible to distinguish the frame that indicate the start of “motion”.
 - You will see the response on the screen generated by the key input.
 - Stop video recording.
- Measurement Location and Luminance Threshold
 - The average luminance level of the measurement region situated in the vertically middle of the display region is measured.
 - The PoC Report shall report the size of the measurement region and the threshold of the luminance level used to determine that the image has changed. Other details should also be reported.

*Note: Take several measurements and find the average as the end result. This is because it depends on the display's timing.

B.2.3 Analysis with High Frame Rate Camera

- Watch the video, find the start frame when the LED is lit, and set it as the starting point (a).
- Find the end frame at the time of UI response and set it as the end point (b).
- Count the number of frames from (b) - (a).

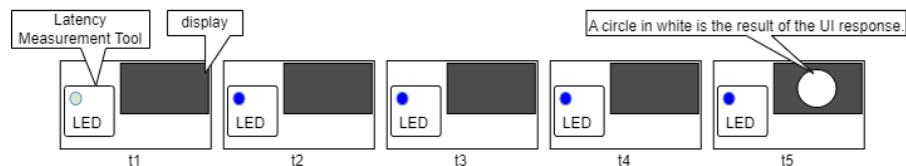

Figure B2.3-1: Analysis with High Frame Rate Camera

*Note: If the image changes slowly and it is difficult to determine the change point, the image change point can be measured objectively with a light sensor and timer.

Annex.C. Scalable Architecture Patterns

This Annex describes the possible architecture patterns to build a scalable N401 Virtual Space Creator component and a high-level comparison among them.

C.1 Possible Architecture Patterns to Build a Scalable Virtual Space Creator Component

This section describes two other possible architectural patterns in addition to the architectural pattern described as PoC configuration in the main body of this document.

C.1.1 Geo-Distributed Implementation of the Virtual Space Creator Component

One possible architecture pattern is using a geo-distributed implementation of the N401 Virtual Space Creator component. Figure C.1-1 shows an image of such an architecture pattern.

In this architecture pattern, physical nodes that jointly construct the Virtual Space Creator components are placed in the regional edge clouds in a distributed manner. The knowledge of the Virtual Space such as spatial partitioning information is loaded in all of these nodes so that the generated Scene Composition Data can be transferred to the appropriate Renderer nodes.

The Virtual Space Creator nodes can be colocated with the Animation Data Generator nodes because their workload is primarily determined by the number of Audience Members connected to the regional edge cloud. So if the server(s) to be used have sufficient resources, these workloads can be executed on the same server(s).

The advantage of this architectural pattern over the one described in the body of this document is that it reduces the distance of data transfer. In particular, users connected to the same regional edge will be visible with low latency. But there are also some drawbacks. One of the drawbacks is that there are too many connections between nodes. This may not be a suitable situation to apply IOWN GF Open APN technology. Another drawback is the necessity to run geo-distributed queries to detect collisions between Audience Members. These would affect performance.

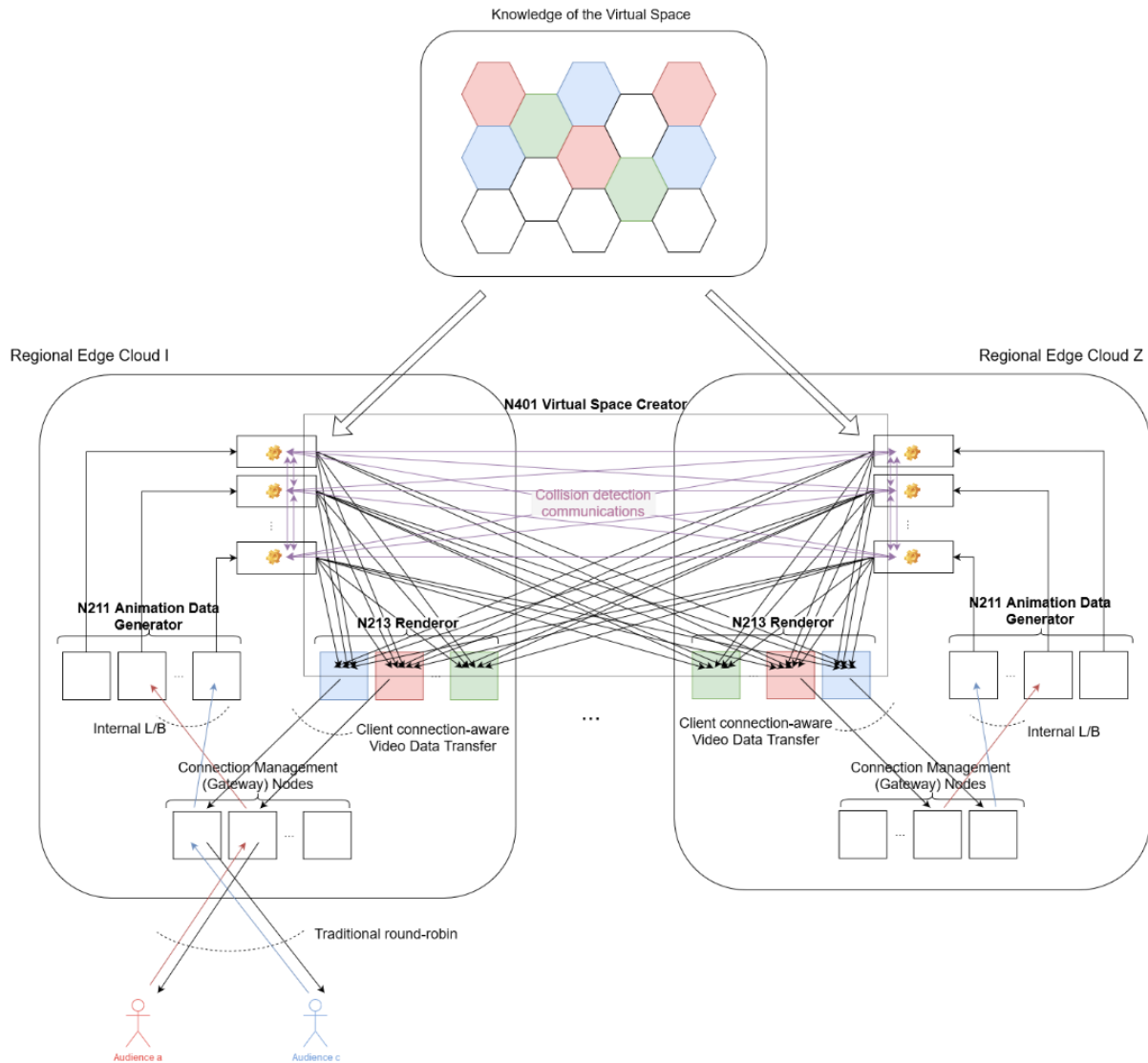

Figure C.1-1: Geo-Distributed Implementation of the Virtual Space Creator

C.1.2 Usage of intelligent clients

Another possible architecture pattern is to make clients intelligent and let them connect to the appropriate node based on the spatial partition assignment. Figure C.1-2 shows an image of such an architecture pattern.

In this architecture pattern, the Animation Data Generator component, Virtual Space Creator component, and Renderer component are all co-located in the same physical nodes. Therefore, as long as the Audience Member stays within the same spatial partition, the number of data transfer hops and the resulting delay can be reduced.

However, there are larger drawbacks. Similar to the previous example, i.e., Geo-distributed implementation of the Virtual Space Creator component architecture pattern, there are too many connections between nodes and the necessity to run geo-distributed queries to detect collisions between Audience Members. In addition, clients need to reconnect to the other node as the Audience Member moves in the virtual space, which would make it difficult to render the field-of-view image smoothly. Also, per-node resource requirements become more severe than other architecture patterns, which may result in a higher cost of the system.

PoC Reference: Reference Implementation Model for the Interactive Live Music Entertainment Use Case

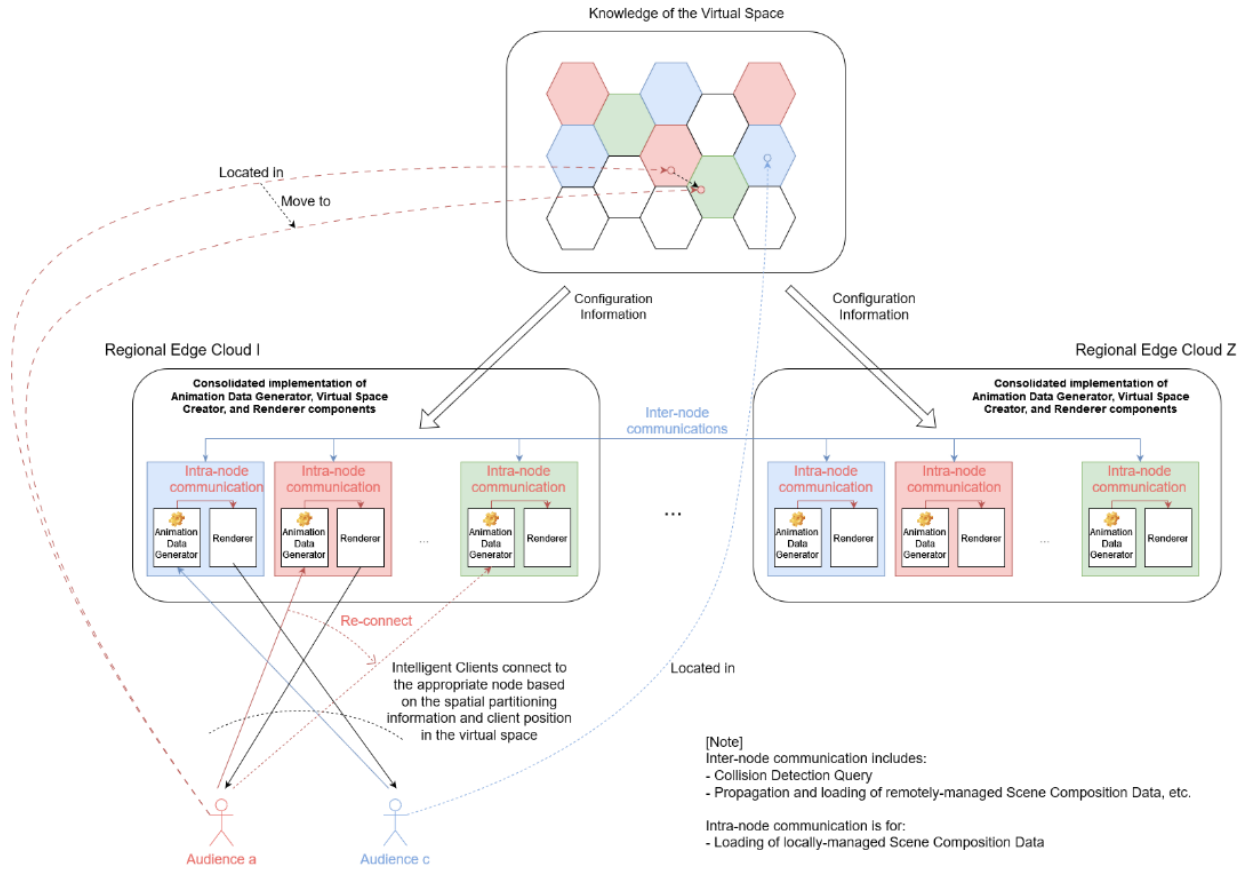

Figure C.1-2: Usage of Intelligent Clients

C.2 Comparison among Possible Architecture Patterns of the Scalable Virtual Space Creator Component

In this Annex, two architectural patterns, i.e., geo-distributed implementation of the Virtual Space Creator component, and usage of intelligent clients, are described in addition to the architectural pattern in the main body of this paper, i.e., a hierarchical implementation of the Virtual Space Creator component with central and regional edge clouds. This section compares these three architectural patterns, and why IOWN Global Forum assumes the hierarchical implementation with central and regional edge clouds as the first PoC candidate.

Evaluation Point	Description	Architecture Pattern		
		Hierarchical Implementation (Section 2.2)	Geo-distributed Implementation (Annex C.1.1)	Usage of Intelligent Clients (Annex C.1.2)
Upper limit of scalability	How largely the system can scale to accommodate more Audience Members	<p>This pattern scales better than other architectural patterns because it requires fewer connections between nodes.</p> <p>Also, once multicasting from the Virtual Space Creator nodes in the central cloud to the renderer nodes in regional edge clouds is realized, this can provide linear scalability to accommodate more Audience Members by adding more regional edge clouds in use.</p>	<p>Scalability will be limited in this pattern compared to the hierarchical implementation because n regional edge clouds must be connected with n-1 other regional edge clouds. In other words, it is difficult to stably connect data centers further apart in a mesh-like manner.</p>	<p>Scalability will be further limited in this compared to the other two patterns because, as with Geo-distributed Implementation, it is necessary to connect n regional edge clouds apart from each other in a mesh manner, and as various processes are colocated on each node, the number of nodes that serve as endpoints in each edge cloud increases, which requires finer mesh links.</p>
Ease of dynamic scalability	How easily/smoothly the system can scale online while continuously providing the service	<p>Three components, i.e., N211 Animation Data Generator, N401 Virtual Space Creator, and N213 Renderer, can be scaled out independently relatively easily:</p> <p>The N211 animation data generator component can scale without worrying about N401 or N213 components.</p> <p>The N401 Virtual Space Creator component can scale by communicating that information to the N211 animation data generator component. Data might be transferred to a old node because of staled spatial partition assignment information, then the problem is resolved by forwarding the data to the appropriate node from the wrong node.</p> <p>The N213 Renderer components can scale by communicating that information to N401 Virtual Space Creator component. The N213 renderer component only renders based on the received animation data, so it only needs to scale before it becomes overloaded.</p>	<p>Dynamic scalability should be conducted based on the number of Audience Members connected to each regional edge cloud, but not on the number of Audience Members in the entire virtual space.</p> <p>The scaling operation per such regional edge cloud must be shared with other regional edge clouds for queries to detect collisions between Audience Members. Therefore, such a scaling operation will be more complex than the one for the hierarchical implementation and may affect the system performance.</p>	<p>Dynamic scalability becomes very difficult, because scaling operations must be informed to each client.</p> <p>Also, each client might start communicating with the new node that reflects the scaling operation at different timing. Therefore, the outbound/inbound data traffic at each node during the scaling operations will become unpredictable. For example, high resolution data is not normally transferred to other nodes within the same regional edge cloud, however it can happen during scale operations. In addition, such an unexpected increase in data traffic may destabilize the service.</p>

<p>Severity of resource requirements</p>	<p>How severe the performance requirements of the nodes that make up the system</p>	<p>In this architecture pattern, the role of each node is clearly separated, so the resource requirements per node are relatively light. Also, unlike other patterns, data queries across data centers are not required, so there is no overhead such as IO Wait related to it, and thus the node performance requirements are lowered.</p>	<p>Compared to the hierarchical implementation, this architectural pattern has little difference in the role split among the nodes, except for the need to run the geo-distributed queries for collision detection. Rather, each node is likely to be smaller than the hierarchical implementation, because data processing like resolution adjustment are distributed across the regional edge clouds. However, It should be noted that there is overhead associated with the need for geo-distributed queries. Therefore, even if the performance requirements of individual nodes become smaller, and this would be true, the overall resource requirements will become severer.</p>	<p>This pattern has the same problem as the geo-distributed implementation described on the left, as this needs to run the geo-distributed queries. In addition, as multiple components need to be colocated on the same node, the performance requirements of each node become severe.</p>
<p>Stability of performance</p>	<p>How stable the system can provide the service</p>	<p>The responsibility boundaries between components are clear, and the load allocation to each node within each component is well balanced, resulting in stable performance. Dynamic scaling operations can also be conducted in a relatively straightforward manner as mentioned above, so the performance will not be disrupted during the scaling operations.</p>	<p>The distributed query to detect collisions between Audience Members will be unstable. This is because query execution time fluctuates from time to time in each node, and the jitter between the regional edge clouds would not be zero considering the challenges in connecting a large number of regional edge clouds in a meshed manner via IOWN GF Open APN. This leads to leaving overlapping among Audience Members for a certain period of time. The Audience Members will have a different experience than the real world.</p>	<p>This pattern has the same problem as the geo-distributed implementation described on the left. Also, more nodes will be needed as resource requirements of each node becomes more severe. This means that the number of connections between nodes will be higher than in the geo-distributed implementation. The situation may adversely affect stability of performance.</p>

<p>Realtime-ness</p>	<p>How quickly the system can render other Audience Members' movements/posture changes</p>	<p>In this pattern, movements and postures of other Audience Members are visualized after transferring animation data to the central cloud and then to the regional edge cloud, so there will always be some delay.</p> <p>In comparison, other architectural patterns may seem to be more real-time because there is no such data transfer if other Audience Members are connected to the same regional edge cloud. However, this isn't true, because it is required to run a geo-distributed query to detect collisions between Audience Members before rendering, which is more unstable and can take longer.</p> <p>On the other hand, it is expected that this architectural pattern runs the data processing involved in a more stable manner. Therefore, it is possible to render the movements and postures of other Audience Members with a constantly small delay.</p>	<p>Queries for collision detection between Audience Members will undermine the realtime-ness of the service. This is because, even when latency between any set of regional edge clouds is stabilized with a power of IOWN GF Open APN, the queries to detect collisions need to wait for a response from the slowest other regional edge cloud, which tends to be unpredictable. And as collision detection queries must be completed to prepare the data for rendering, there will be a considerable delay in generating the field-of-view for the Audience Member. This is not good for the user experience.</p>	<p>This pattern has the same problem as the geo-distributed implementation described on the left.</p> <p>Additionally, in this pattern, collision detection queries need to run on top of more nodes than the geo-distributed implementation pattern. This may further worsen the realtime-ness.</p>
----------------------	--	--	---	--

Table C2-1: Architecture Pattern Comparison

As summarized in Table C.2, the hierarchical implementation of the Virtual Space Creator component has various advantages over other architectural patterns in various aspects. Therefore, as the first implementation candidate for the Interactive Live Music service, the hierarchical implementation of the Virtual Space Creator component is assumed.

7. Acknowledgments

This Reference Document was jointly prepared by Technical and Use Case working group on the IOWN GF under the direction of Masahisa Kawashima (Technical WG Chair) and Katsutoshi Ito (Use Case WG Chair).

The management team is listed here, followed by contributors in alphabetical order.

Dr Masahisa Kawashima, NTT, Technical WG Chair

Mr. Katsutoshi Ito, Sony Corporation, Use Case WG Chair

8. History

Revision	Release Date	Summary of Changes
1	December 2023	Initial Version