



**IOWN**  
GLOBAL FORUM™

# Reference Implementation Model and Proof-of-Concept Reference of Remote Media Production for Broadcast Industry

---

Classification: APPROVED REFERENCE DOCUMENT

Confidentiality: PUBLIC

Version 1

December 2024

[Remote Media Production RIM PoC Ref]

## Legal

THIS DOCUMENT HAS BEEN DESIGNATED BY THE INNOVATIVE OPTICAL AND WIRELESS NETWORK GLOBAL FORUM, INC. (“IOWN GLOBAL FORUM”) AS AN APPROVED REFERENCE DOCUMENT AS SUCH TERM IS USED IN THE IOWN GLOBAL FORUM INTELLECTUAL PROPERTY RIGHTS POLICY (THIS “REFERENCE DOCUMENT”).

THIS REFERENCE DOCUMENT IS PROVIDED “AS IS” WITH NO WARRANTIES WHATSOEVER, WHETHER EXPRESS, IMPLIED, STATUTORY, OR OTHERWISE, INCLUDING WITHOUT LIMITATION ANY WARRANTY OF MERCHANTABILITY, NONINFRINGEMENT OF THIRD PARTY RIGHTS, TITLE, VALIDITY OF RIGHTS IN, FITNESS FOR ANY PARTICULAR PURPOSE, OR ANY WARRANTY OTHERWISE ARISING OUT OF ANY PROPOSAL, REFERENCE DOCUMENT, SAMPLE, OR LAW. WITHOUT LIMITATION, IOWN GLOBAL FORUM DISCLAIMS ALL LIABILITY, INCLUDING WITHOUT LIMITATION LIABILITY FOR INFRINGEMENT OF ANY PROPRIETARY RIGHTS AND PRODUCTS LIABILITY, RELATING TO USE OF THE INFORMATION IN THIS REFERENCE DOCUMENT AND TO ANY USE OF THIS REFERENCE DOCUMENT IN CONNECTION WITH THE DEVELOPMENT OF ANY PRODUCT OR SERVICE, AND IOWN GLOBAL FORUM DISCLAIMS ALL LIABILITY FOR COST OF PROCUREMENT OF SUBSTITUTE GOODS OR SERVICES, LOST PROFITS, LOSS OF USE, LOSS OF DATA OR ANY INCIDENTAL, CONSEQUENTIAL, DIRECT, INDIRECT, PUNITIVE, EXEMPLARY, OR SPECIAL DAMAGES, WHETHER UNDER CONTRACT, TORT, WARRANTY OR OTHERWISE, ARISING IN ANY WAY OUT OF USE OR RELIANCE UPON THIS REFERENCE DOCUMENT OR ANY INFORMATION HEREIN.

EXCEPT AS EXPRESSLY SET FORTH IN THE PARAGRAPH DIRECTLY BELOW, NO LICENSE IS GRANTED HEREIN, EXPRESS OR IMPLIED, BY ESTOPPEL OR OTHERWISE, TO ANY INTELLECTUAL PROPERTY RIGHTS OF THE IOWN GLOBAL FORUM, ANY IOWN GLOBAL FORUM MEMBER OR ANY AFFILIATE OF ANY IOWN GLOBAL FORUM MEMBER. EXCEPT AS EXPRESSLY SET FORTH IN THE PARAGRAPH DIRECTLY BELOW, ALL RIGHTS IN THIS REFERENCE DOCUMENT ARE RESERVED.

A limited, non-exclusive, non-transferable, non-assignable, non-sublicensable license is hereby granted by IOWN Global Forum to you to copy, reproduce, and use this Reference Document for internal use only. You must retain this page and all proprietary rights notices in all copies you make of this Reference Document under this license grant.

THIS DOCUMENT IS AN APPROVED REFERENCE DOCUMENT AND IS SUBJECT TO THE REFERENCE DOCUMENT LICENSING COMMITMENTS OF THE MEMBERS OF THE IOWN GLOBAL FORUM PURSUANT TO THE IOWN GLOBAL FORUM INTELLECTUAL PROPERTY RIGHTS POLICY. A COPY OF THE IOWN GLOBAL FORUM INTELLECTUAL PROPERTY RIGHTS POLICY CAN BE OBTAINED BY COMPLETING THE FORM AT: [www.iowngf.org/join-forum](http://www.iowngf.org/join-forum). USE OF THIS REFERENCE DOCUMENT IS SUBJECT TO THE LIMITED INTERNAL-USE ONLY LICENSE GRANTED ABOVE. IF YOU WOULD LIKE TO REQUEST A COPYRIGHT LICENSE THAT IS DIFFERENT FROM THE ONE GRANTED ABOVE (SUCH AS, BUT NOT LIMITED TO, A LICENSE TO TRANSLATE THIS REFERENCE DOCUMENT INTO ANOTHER LANGUAGE), PLEASE CONTACT US BY COMPLETING THE FORM AT: <https://iowngf.org/contact-us/>

Copyright © 2024 Innovative Optical Wireless Network Global Forum, Inc. All rights reserved. Except for the limited internal-use only license set forth above, copying or other forms of reproduction and/or distribution of this Reference Document are strictly prohibited.

The IOWN GLOBAL FORUM mark and IOWN GLOBAL FORUM & Design logo are trademarks of Innovative Optical and Wireless Network Global Forum, Inc. in the United States and other countries. Unauthorized use is strictly prohibited. IOWN is a registered and unregistered trademark of Nippon Telegraph and Telephone Corporation in the United States, Japan, and other countries. Other names and brands appearing in this document may be claimed as the property of others.

## Contents

|   |           |
|---|-----------|
| <b>1. Introduction</b> .....  | <b>4</b>  |
| 1.1. Project Objective .....  | 4         |
| 1.2. Document Scope .....   | 4         |
| <b>2. Reference Implementation Models</b> .....                                       | <b>5</b>  |
| 2.1. Basic Strategy of System Architecture and Design .....                           | 5         |
| 2.2. Reference Implementation Model for UC#1: Media Production from Remote Site ..... | 5         |
| 2.2.1. System Architecture .....  | 5         |
| 2.2.2. Functional Nodes .....   | 6         |
| 2.2.3. Data Pipeline .....  | 6         |
| 2.3. Reference Implementation Model for UC#2: Network Resource Sharing .....          | 7         |
| 2.3.1. System Architecture .....  | 7         |
| 2.3.2. Functional Nodes .....   | 8         |
| 2.3.3. Data Pipeline .....  | 9         |
| 2.4. Reference Implementation Model for UC#3: Media Production Resource Sharing ..... | 9         |
| 2.4.1. System Architecture .....  | 10        |
| 2.4.2. Functional Nodes .....   | 10        |
| 2.4.3. Data Pipeline .....  | 11        |
| <b>3. PoC Reference</b> .....   | <b>13</b> |
| 3.1. PoC Reference for UC#1: Media Production from Remote Site .....                  | 13        |
| 3.2. PoC Reference for UC#2: Network Resource Sharing .....                           | 14        |
| 3.3. PoC Reference for UC#3: Media Production Resource Sharing .....                  | 15        |
| <b>4. Conclusion</b> .....  | <b>18</b> |
| <b>5. Appendix A. References</b> .....  | <b>19</b> |
| <b>6. Appendix B. Terms and Definitions</b> .....                                     | <b>20</b> |
| <b>7. Appendix C. Examples of Implementation Models</b> .....                         | <b>21</b> |
| 7.1. Open APN-based WAN .....   | 21        |
| 7.2. Redundancy .....   | 24        |
| <b>History</b> .....  | <b>25</b> |

## 1. Introduction

The rapid advancement of media production technology makes it incredibly challenging to secure enough highly skilled and qualified media production operators to meet demand, especially in rural areas. This lack of skilled personnel, limited resources for acquiring advanced solutions, and high networking cost make distributing and developing quality content a daunting prospect. As a result, there is significant demand for new solutions and architectures that provide a more optimal profit structure to address these new market realities.

Among the highly advanced IOWN GF technologies available to broadcasters, Open All-Photonic Networks (Open APNs) provide some of the most impactful results. Open APNs, which primarily rely on photonics (using laser light rather than electricity) as the basis for data transmission, can provide high-bandwidth and low-latency connections to enable network-demanding applications such as high-quality video production while achieving high flexibility and dynamicity for cost optimization.

By utilizing IOWN GF technologies, an operator(s) who manipulates the media essence for live broadcasting will be able to remotely control the media production resources, such as production switcher and editor, as if the operator and the media production resource were together at the same site. The flexible workstyle enabled by this model will help secure highly skilled and qualified media production professionals who may be geographically distributed.

IOWN GF technologies can offer the broadcast industry the required flexibility and performance gains in a cost-conscious manner through its on-demand purchase models, in contrast to the conventional installation of dedicated lines.

Moreover, they will operate with far less energy consumption than today's networks, contributing to further reduction of operation costs.

Furthermore, IOWN GF technologies will enable the sharing and consolidation of top-end equipment, significantly reducing both CAPEX and OPEX while improving the agility and flexibility of the media production workflow.

### 1.1. Project Objective

The objective of the Remote Media Production with IOWN GF technologies project is to define a reference design that will allow media broadcasters to create content in a cost-effective new architecture, while bringing exciting new capabilities to meet today's content development challenges.

The scope of this project is to:

1. Describe the Remote Media Production Use Case and its key requirements
2. Define the Technology Evaluation Criteria, which include reference cases and key benchmarks
3. Develop the Reference Implementation Model (RIM), which provides practical implementation of IOWN Technologies as a reference model to realize the use case
4. Define the Proof of Concept (PoC) Reference, which provides guidelines for conducting PoCs for the use case to evaluate the RIM with the defined Technology Evaluation Criteria
5. Run and evaluate the PoC based on the PoC Reference

### 1.2. Document Scope

1 and 2, listed in the above section, are completed and the outcome is explained in the "Remote Media Production for Broadcast Industry Use Case" document [1].

As a subsequent document, this will cover 3 and 4, to engage early adopters in the broadcast industry.

The following sections of this document will describe the data flow and workloads analysis, a RIM for Remote Media Production with IOWN GF technologies, and define their system validation testing and performance benchmark, and last, PoC references.

## 2. Reference Implementation Models

This section describes RIMs for each use cases. These RIMs are designed as a generalized system architecture so that PoC Conductors can propose a suitable architecture based on the RIM using IOWN GF technologies. Also, in order to focus on the WAN configuration utilizing Open APN, on-premise equipment is simplified as only one production switcher is described as Media Production Resources although many Media Production Resources such as editor, audio mixer and video server may be used in today's media production. Additional Media Production Resources other than a production switcher could be used in the PoC.

The RIMs defined below use a term, Open APN-based WAN. Open APN-based WAN is defined as any network that uses Open APN for long-haul data transport. Some Open APN-based WAN may use packet switches to improve the flexibility and dynamicity of services. PoC implementers are expected to design a network with the best benchmark score, taking advantage of this design freedom.

### 2.1. Basic Strategy of System Architecture and Design

The basic design strategy is to utilize Open APN's dynamic optical path provisioning/control feature [2] and on-demand purchase models as mentioned in the whitepaper [3], to reduce the connectivity cost compared with conventional fixed site-to-site connectivity, while meeting stringent requirements like latency and bandwidth. In order to further reduce the cost, use of PtMP APN, aggregation of NWs from multiple sites, or consolidation of NW equipment may be considered.

### 2.2. Reference Implementation Model for UC#1: Media Production from Remote Site

This section describes the reference implementation model, which contains the system architecture, the detail of main functional nodes and the profile of data pipeline that focuses on the WAN part for UC#1. The role of Open APN in this use case is to transport a video stream for monitor and control data between a remote office and a broadcast station without delay and interruptions in cost-effective manner to give an human operator an optimal remote working environment.

#### 2.2.1. System Architecture

Figure 2.2.1-1 shows the system architecture for UC#1. For Open APN-based WAN, Open APN should be utilized to contribute to the cost-effectiveness while satisfying the key requirements. Some implementation examples of Open APN-based WAN are described in Appendix C as a reference. PoC Conductors can choose one of them or they can design their own implementation model. For LAN configuration, it is not focused in this document but it should be carefully designed to minimize the transmission delay of media streams. Regarding the scale of the system, please refer to the section 4.1 of the use case document [1].

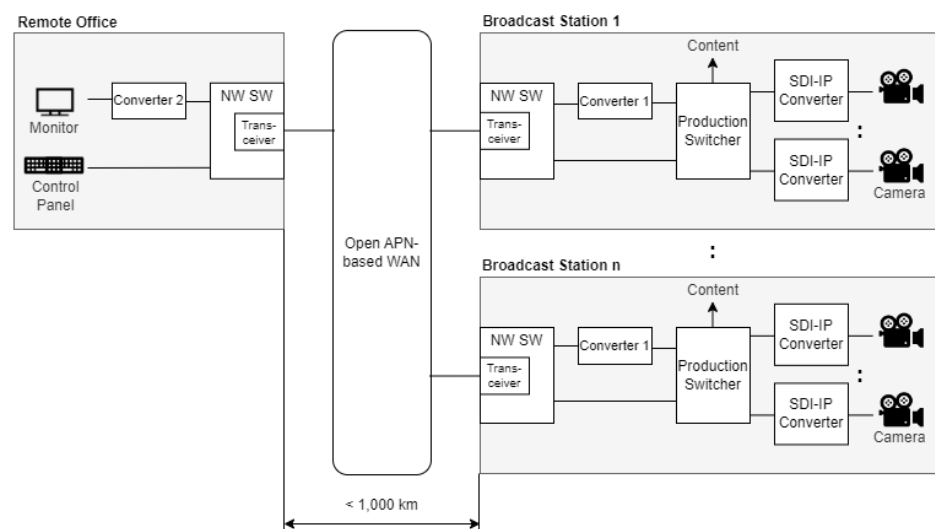

Figure 2.2.1-1 Reference System Architecture for UC#1

### 2.2.2. Functional Nodes

Table 2.2.2-1 describes the functional nodes that are important in the reference implementation model. The functional nodes are logical components and they could be merged into one hardware or software.

Table 2.2.2-1 Node Profile of UC#1: Media Production from Remote Site

| NAME                | DESCRIPTION  | ATTRIBUTES   |
|---------------------|--|--|
| Production Switcher | <p>This equipment switches media essence streams from multiple Cameras to produce the media essence stream for distribution. This also produces a multi-view video stream for monitoring.</p> <p>In addition, this equipment may have editing functions such as composition, adding text and overlay images.</p> <p>This is controlled by Control Panel.</p> | <ul style="list-style-type: none"> <li>Place: Broadcast Station</li> <li>Interface: ethernet</li> <li>#: 1 per site</li> </ul>           |
| Converter 1         | <p>This is a media conversion device that optionally has a low-latency video encoder such as JPEG XS.</p> <p>In the case of JPEG XS, this converts from ST2110-20 (uncompressed video stream) to ST2110-22 (JPEG XS).</p>  | <ul style="list-style-type: none"> <li>Place: Broadcast Station</li> <li>Interface: ethernet</li> <li>#: 1 per site</li> </ul>           |
| Converter 2         | <p>This is a media conversion device that has an IP-SDI converter and this optionally has a low-latency video decoding function such as JPEG XS.</p>   | <ul style="list-style-type: none"> <li>Place: Remote Office</li> <li>Interface: BNC(out), ethernet(in)</li> <li>#: 1 per site</li> </ul> |
| Monitor             | Monitor for switching / editing  | <ul style="list-style-type: none"> <li>Place: Remote Office</li> <li>Interface: BNC</li> <li>#: 1 per site</li> </ul>                    |
| Control Panel       | Control Panel for switching / editing  | <ul style="list-style-type: none"> <li>Place: Remote Office</li> <li>Interface: ethernet</li> <li>#: 1 per site</li> </ul>               |

### 2.2.3. Data Pipeline

Figure 2.2.3-1 shows the Data Pipeline Diagram (hereafter DPD) of UC#1: Media Production from Remote Office. In this case, Operator(s) who are in a Remote Office conducts media production using a monitor and a control panel that are connected to a production switcher at a Broadcast Station via WAN. Table 2.2.3-1 describes the data profile for the DPD.

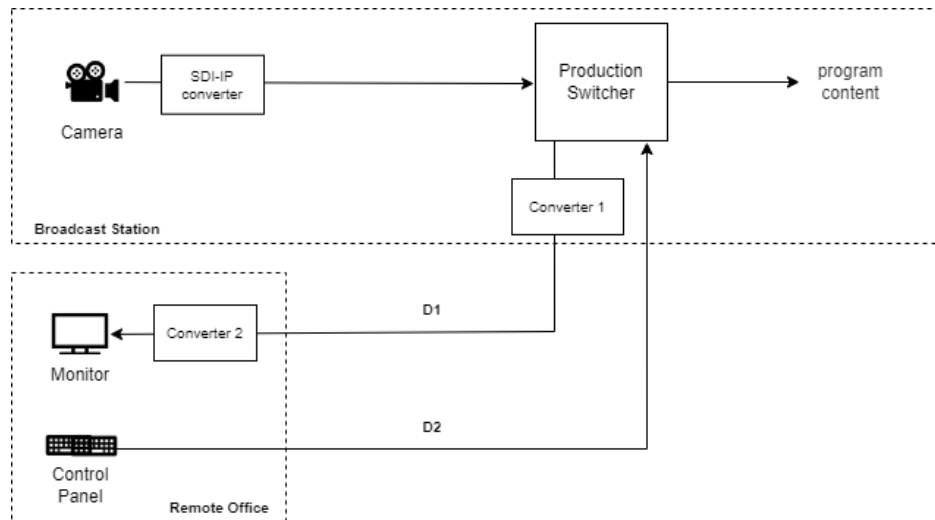

Figure 2.2.3-1: Data Pipeline Diagram for UC#1: Media Production from Remote Site

Table 2.2.3-1 Dataflow Profile of UC#1: Media Production from Remote Site

| ID | DESCRIPTION                       | ATTRIBUTES  |
|----|-----------------------------------|---|
| D1 | Media essence streams for monitor | <ul style="list-style-type: none"> <li>• # of sources: 1</li> <li>• Bitrate: e.g. 1.2Gbps (4K60p video stream using JPEG XS compression) or 12Gbps (4K60p uncompressed video stream)</li> <li>• Protocol: SMPTE ST2110 [4]</li> </ul> |
| D2 | Control data                      | <ul style="list-style-type: none"> <li>• # of sources: 1</li> <li>• Bitrate: <ul style="list-style-type: none"> <li>○ &lt;1Mbps</li> </ul> </li> <li>• Protocol: ip-based (proprietary)</li> </ul>                                    |

### 2.3. Reference Implementation Model for UC#2: Network Resource Sharing

This section describes the reference implementation model for UC#2. The role of Open APN in this use case is to transport the high-rate multiple media streams without delay and interruptions from an event venue to a broadcast station. In addition, sharing the network between event venues and broadcast stations utilizing Open APN's dynamic path provisioning feature is expected to significantly reduce the system cost.

#### 2.3.1. System Architecture

Figure 2.3.1-1 shows the system architecture for UC#2. For Open APN-based WAN, Open APN should be utilized to contribute to the cost-effectiveness while satisfying the key requirements. Some implementation examples of Open APN-based WAN are described in Appendix C as a reference. PoC Conductors can choose one of them or they can design their own implementation model. For LAN configuration, there is no critical requirement and it could be designed like today's media production systems. Regarding the scale of the system, please refer to the section 4.1 of the use case document [1].

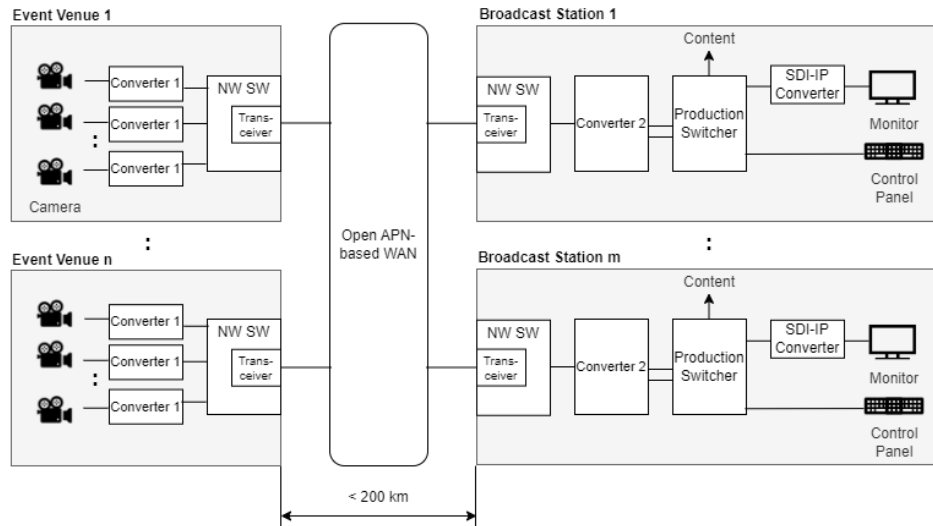

Figure 2.3.1-1 Reference System Architecture for UC#2

### 2.3.2. Functional Nodes

Table 2.3.2-1 describes the functional nodes that are important in the reference implementation model. The functional nodes are logical components and they could be merged into one hardware or software.

Table 2.3.2-1 Node Profile of UC#2: Network Resource Sharing

| NAME                | DESCRIPTION  | ATTRIBUTES   |
|---------------------|--|--|
| Camera              | Professional camera that has a SDI interface.  | <ul style="list-style-type: none"> <li>Place: Event Venue</li> <li>Interface: BNC</li> <li>#: 1-50 (2K cameras) / 1-12 (4K cameras)</li> </ul> |
| Converter 1         | <p>This is a media conversion device that has an SDI-IP converter and a low-latency video encoding function such as JPEG XS.</p> <p>In the case of JPEG XS, this converts from ST2110-20 (uncompressed video stream) to ST2110-22 (JPEG XS).</p>   | <ul style="list-style-type: none"> <li>Place: Event Venue</li> <li>Interface: BNC(in), ethernet(out)</li> <li>#: (equals to N5)</li> </ul>     |
| Converter 2         | This is a media conversion device that has an IP-SDI converter and a low-latency video decoding function such as JPEG XS.  | <ul style="list-style-type: none"> <li>Place: Broadcast Station</li> <li>Interface: ethernet</li> <li>#: 1 per site</li> </ul>                 |
| Production Switcher | <p>This equipment switches media essence streams from multiple Cameras to produce the media essence stream for distribution. This also produces a multi-view video stream for monitoring.</p> <p>In addition, this equipment may have editing functions such as composition, adding text and overlay images.</p> <p>This is controlled by Control Panel.</p> | <ul style="list-style-type: none"> <li>Place: Broadcast Station</li> <li>Interface: ethernet</li> <li>#: 1</li> </ul>                          |

### 2.3.3. Data Pipeline

Figure 2.3.3-1 shows the DPD of UC#2: Network Resource Sharing. For this DPD, it assumes that a WAN link is established between a Event Venue and a Broadcast Station. Cameras that are used for shooting at Event Venue generates media essence streams such as video and audio streams and they are sent to the production switcher at a Broadcast Station via WAN. Table 2.3.3-1 describes the data profile for the DPD.

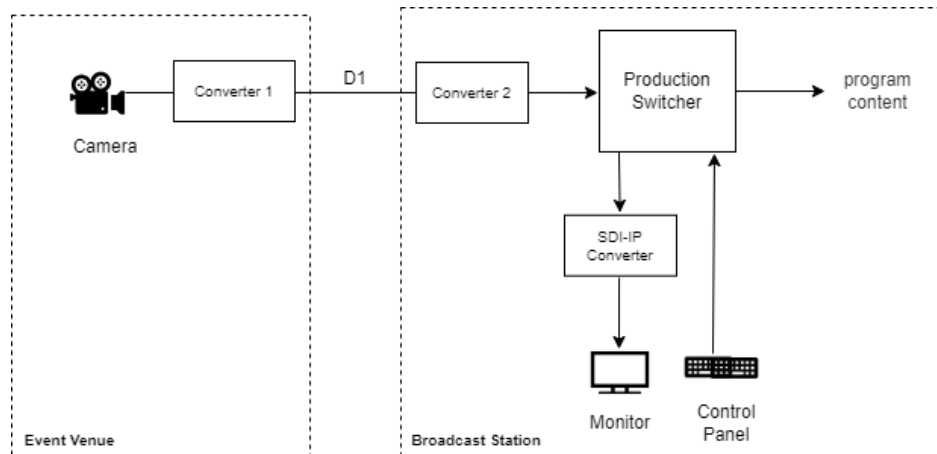

Figure 2.3.3-1: Data Pipeline Diagram of UC#2: Network Resource Sharing

Table 2.3.3-1 Dataflow Profile of UC#2: Network Resource Sharing

| ID | DESCRIPTION           | ATTRIBUTES   |
|----|-----------------------|--|
| D1 | Media essence streams | <ul style="list-style-type: none"> <li>• # of sources:                             <ul style="list-style-type: none"> <li>○ ~50 (2K cameras)</li> <li>○ ~12 (4K cameras)</li> </ul> </li> <li>• Bitrate:                             <ul style="list-style-type: none"> <li>○ total: &lt; 20Gbps                                     <ul style="list-style-type: none"> <li>▪ e.g. 0.3Gbps (2K60p video stream using JPEG XS compression)</li> <li>▪ e.g. 1.2Gbps (4K60p video stream using JPEG XS compression)</li> <li>▪ e.g. 12Gbps (4K60p uncompressed video stream)</li> </ul> </li> </ul> </li> <li>• Protocol: SMPTE ST2110</li> </ul> |

### 2.4. Reference Implementation Model for UC#3: Media Production Resource Sharing

This section describes the reference implementation model for UC#3. The role of Open APN in this use case is to transport a video stream for monitor, control data and the high-rate multiple media streams without delay and interruptions between broadcast stations and a media production center.

In addition, sharing the network between broadcast stations and the media production center utilizing Open APN's dynamic path provisioning feature is expected to significantly reduce the system cost.

### 2.4.1. System Architecture

Figure 2.4.1-1 shows the system architecture for UC#3. For Open APN-based WAN, Open APN should be utilized to contribute to the cost-effectiveness while satisfying the key requirements. Some implementation examples of Open APN-based WAN are described in Appendix C as a reference. PoC Conductors can choose one of them or they can design their own implementation model. For LAN configuration, there is no critical requirement and it could be designed like today’s media production systems. Regarding the scale of the system, please refer to the section 4.1 of the use case document [1].

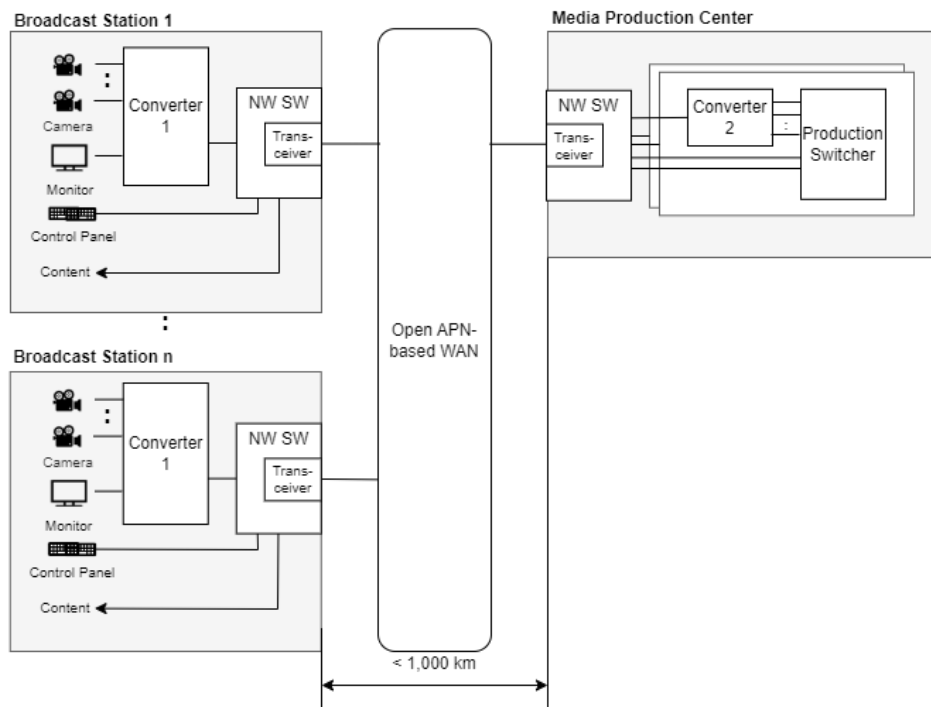

Figure 2.4.1-1 Reference System Architecture for UC#3

### 2.4.2. Functional Nodes

Table 2.4.2-1 describes the functional nodes that are important in the reference implementation model. The functional nodes are logical components, and they could be merged into one hardware or software.

Table 2.4.2-1 Node Profile of UC#3: Media Production Resource Sharing

| NAME                | DESCRIPTION  | ATTRIBUTES   |
|---------------------|--|--|
| Production Switcher | <p>This equipment switches media essence streams from multiple Cameras to produce the media essence stream for distribution. This also produces a multi-view video stream for monitoring.</p> <p>In addition, this equipment may have editing functions such as composition, adding text and overlay images.</p> <p>This is controlled by Control Panel.</p> | <ul style="list-style-type: none"> <li>Place: Media Production Center</li> <li>Interface: ethernet</li> <li>#: 1 per site</li> </ul> |

|               |   |  |
|---------------|---|--|
| Converter 1   | <p>This is a media conversion device that has an SDI-IP converter and a low-latency video encoding/decoding function such as JPEG XS.</p> <p>In the case of JPEG XS, this converts from ST2110-20 (uncompressed video stream) to ST2110-22 (JPEG XS).</p> | <ul style="list-style-type: none"> <li>Place: Broadcast Station</li> <li>Interface: BNC(in) for Camera, BNC(out) for Monitor, ethernet(out) for others</li> <li>#: 1 per site</li> </ul> |
| Converter 2   | <p>This is a media conversion device that has a low-latency video encoding/decoding function such as JPEG XS.</p>   | <ul style="list-style-type: none"> <li>Place: Media Production Center</li> <li>Interface: ethernet</li> <li>#: 1 per site</li> </ul>   |
| Camera        | <p>Professional camera that has a SDI interface.</p>  | <ul style="list-style-type: none"> <li>Place: Broadcast Station</li> <li>Interface: BNC</li> <li>#: 1-50 (2K cameras) / 1-12 (4K cameras)</li> </ul>                                     |
| Monitor       | <p>Monitor for switching / editing</p>  | <ul style="list-style-type: none"> <li>Place: Broadcast Station</li> <li>Interface: BNC</li> <li>#: 1 per site</li> </ul>  |
| Control Panel | <p>Control Panel for switching / editing</p>  | <ul style="list-style-type: none"> <li>Place: Broadcast Station</li> <li>Interface: ethernet</li> <li>#: 1 per site</li> </ul>   |

### 2.4.3. Data Pipeline

Figure 2.4.3-1 shows the DPD of UC#3: Media Production Resource Sharing. This diagram shows the dataflow when one production switcher at the Media Production Center is allocated to a Broadcast Station. Other resources such as cameras, a monitor and a control panel are located at a Broadcast Station. They are connected to the production switcher via WAN. Table 2.4.3-1 describes the data profile for the DPD.

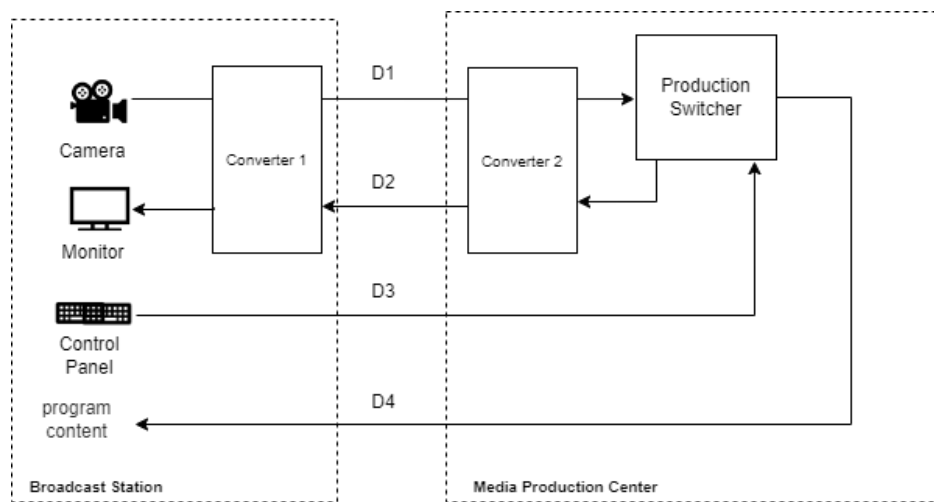

Figure 2.4.3-1: Data Pipeline Diagram of UC#3: Media Production Resource Sharing

Table 2.4.3-1 Dataflow Profile of UC#3: Media Production Resource Sharing

| ID | DESCRIPTION   | ATTRIBUTES   |
|----|---|--|
| D1 | Media essence streams   | <ul style="list-style-type: none"> <li>• # of sources: <ul style="list-style-type: none"> <li>○ ~50 (2K cameras)</li> <li>○ ~12 (4K cameras)</li> </ul> </li> <li>• Bitrate: <ul style="list-style-type: none"> <li>○ total: &lt; 20Gbps <ul style="list-style-type: none"> <li>▪ e.g. 0.3Gbps (2K60p video stream using JPEG XS compression)</li> <li>▪ e.g. 1.2Gbps (4K60p video stream using JPEG XS compression)</li> <li>▪ e.g. 12Gbps (4K60p uncompressed video stream)</li> </ul> </li> </ul> </li> <li>• Protocol: SMPTE ST2110</li> </ul> |
| D2 | Media essence streams for monitor                                   | <ul style="list-style-type: none"> <li>• # of sources: 1</li> <li>• Bitrate: <ul style="list-style-type: none"> <li>○ e.g. 1.2Gbps (4K60p video stream using JPEG XS compression)</li> </ul> </li> <li>• Protocol: SMPTE ST2110</li> </ul>   |
| D3 | Control data  | <ul style="list-style-type: none"> <li>• # of sources: 1</li> <li>• Bitrate: <ul style="list-style-type: none"> <li>○ &lt;1Mbps</li> </ul> </li> <li>• Protocol: ip-based (proprietary)</li> </ul>   |
| D4 | Media essence stream out from Production Switcher (program content) | <ul style="list-style-type: none"> <li>• # of sources: 1</li> <li>• Bitrate: <ul style="list-style-type: none"> <li>○ e.g. 0.3Gbps (2K60p video stream using JPEG XS compression)</li> <li>○ e.g. 1.2Gbps (4K60p video stream using JPEG XS compression)</li> <li>○ e.g. 12Gbps (4K60p uncompressed video stream)</li> </ul> </li> <li>• Protocol: SMPTE ST2110</li> </ul>   |

### 3. PoC Reference

In this section, we define PoC References for each of the use cases with the technology evaluation criteria described in Section 4 of “Remote Media Production for Broadcast Industry Use Case” document [1] and the Reference Implementation Models defined in the previous section.

The reference cases in the technology evaluation criteria in Section 4.1 of “Remote Media Production for Broadcast Industry Use Case” document [1] define the specific conditions that meet the key requirements for accurately evaluating the reference implementation model for the use cases.

The PoC References in this section describe the methods for validating the key requirements and evaluating metrics for benchmarking. The key requirements are the objective criteria that need to be met in PoCs to realize Remote Media Production use cases, and the better values of metrics for benchmarking indicate that the PoC is performed with more desirable implementation for users. It is important to note that the contents described here provide useful information on evaluating PoCs, rather than established rules or regulations.

#### 3.1. PoC Reference for UC#1: Media Production from Remote Site

This section describes the items for validation testing and benchmark for UC#1. PoC Conductor must conduct this PoC for the reference case defined in section 4.1.1 of [1], implementing a system that satisfies the key requirements in section 3 of [1]. The proposed implementation model and the results of the validation testing and benchmark should be reported.

- **Validation Testing: Network delay time**
  - **Prerequisites for Evaluation**
    - The WAN link is established between a Broadcast Station and a Remote Site. All devices and nodes are running and it is ready to conduct the Remote Media Production.
    - As for the network distance of the WAN, a network emulator or similar equipment could be used to emulate the long distance network.
  - **Metrics**
    - Delay time T1 and T2 in msec
  - **Evaluation Methods**
    - The delay time should be measured by using a measurement tool that can measure the delay time on L2/L3 or media layer (e.g. SMPTE ST2110).
  - **Points to Verify**
    - Network delay time caused by the remote operation (T1+T2) specified in the Figure 3.1-1 is less than 16.6 ms. (Note: this time should contain the time delay of network elements such as NW SW.)

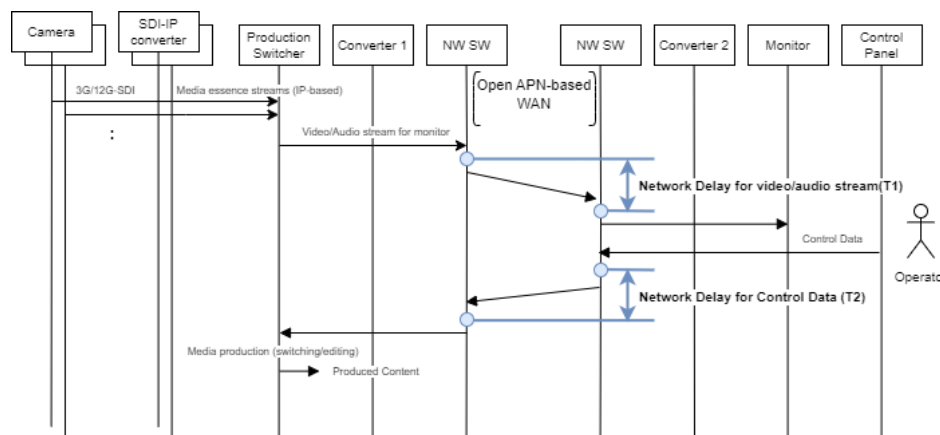

Figure 3.1-1 Simplified Sequence Chart for UC#1

- **Benchmark Testing: WAN availability**
  - **Prerequisites**

- PoC Conductor designs the WAN configuration utilizing Open APN that satisfies the key requirements based on the availability information of NW and NW equipment.
    - The WAN link is established between a Broadcast Station and a Remote Site. All devices and nodes are running and Operator can conduct the Remote Media Production.
  - **Metrics**
    - Downtime (meantime to repair) in msec.  
Note: The measurement of availability requires long-time and statistical measurements. Therefore, it is not an effective way to measure it in this PoC activity. Instead, the downtime should be measured by intentionally causing a communication failure in WAN section which is designed considering the availability requirement.
  - **Benchmark Method**
    - PoC Conductor should measure the downtime of the WAN on the proposed system by making the WAN link down. If a redundant network is used, it should be measured when one of the network link is down.
    - The downtime should be measured by using a measurement tool that can measure the downtime in L2/L3 or media layer. Instead of measuring the downtime, it is allowed to estimate the downtime from other metrics such as the number of dropped packets during the downtime.
  - **Points to Benchmark**
    - From the downtime, the number of dropped video frames that impacts on the live media production could be estimated. In the live media production, the downtime should be minimized to produce high-quality content while cost-effective solution is also needed for economic feasibility.
- **Benchmark Testing: System/Operation cost**
  - **Prerequisites**
    - (none)
  - **Metrics**
    - Resources required for media production that affects on the system and operation costs (e.g. media production resources and personnel costs and the required network resources such as the number of optical cables, information about their distance and bandwidth, network elements such as switches and transceivers.)
  - **Benchmark Method**
    - Estimate the required resources for media production based on the Technology Evaluation Criteria as described in the UC document [1].
    - It is recommended to compare it with the case of media production on premises.

### 3.2. PoC Reference for UC#2: Network Resource Sharing

This section describes the items for validation testing and benchmark for UC#2. PoC Conductor must conduct this PoC for the reference case defined in section 4.1.2 of [1], implementing a system that satisfies the key requirements in section 3 of [1]. The proposed implementation model and the results of the validation testing and benchmark should be reported.

- **Validation Testing: Network delay time**
  - **Prerequisites for Evaluation**
    - The WAN link is established between an Event Venue and a Broadcast Station. All devices and nodes are running and it is ready to conduct the Remote Media Production.
    - As for the network distance of the WAN, a network emulator or similar equipment could be used to emulate the long distance network.
  - **Metrics**
    - Delay time T1 in msec
  - **Evaluation Methods**
    - The delay time should be measured by using a measurement tool that can measure the delay time on L2/L3 or media layer.
  - **Points to Verify**
    - Network delay time of media essence stream (T1) as specified in the Figure 3.2-1 is less than 16.6 ms. (Note: this time should contain the time delay of network elements such as NW SW.)

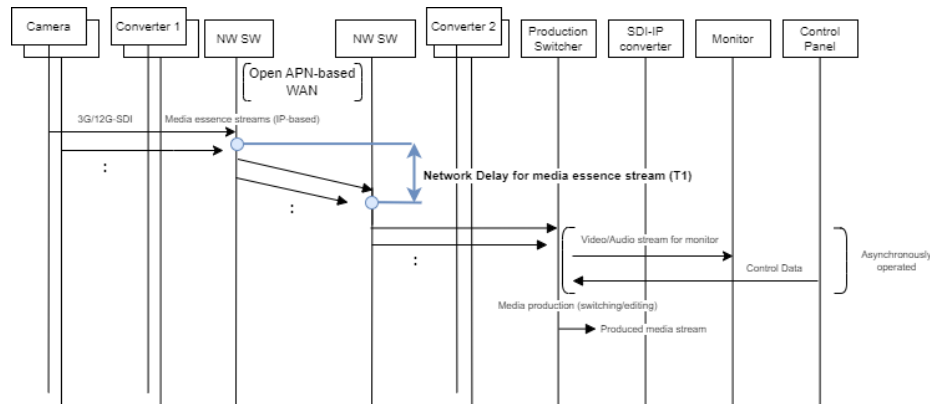

Figure 3.2-1 Simplified Sequence Chart for UC#2

- **Benchmark Testing: System/Operation cost**
  - **Prerequisites**
    - (none)
  - **Metrics**
    - Resources required for media production that affects on the system and operation costs (e.g. media production resources and personnel costs and the required network resources such as the number of optical cables, information about their distance and bandwidth, network elements such as switches and transceivers.)
  - **Benchmark Method**
    - Estimate the required resources for media production based on the Technology Evaluation Criteria as described in the UC document [1].
    - It is recommended to compare it with the case of media production on premises.

### 3.3. PoC Reference for UC#3: Media Production Resource Sharing

This section describes the items for validation testing and benchmark for UC#3. PoC Conductor may conduct this PoC for the reference case defined in section 4.1.3 of [1], implementing a system that satisfies the key requirements in section 3 of [1]. The proposed implementation model and the results of the validation testing and benchmark should be reported.

- **Validation Testing: Network delay time**
  - **Prerequisites for Evaluation**
    - The WAN link is established between a Broadcast Station and a Media Production Center. All devices and nodes are running and it is ready to conduct the Remote Media Production.
    - As for the network distance of the WAN, a network emulator or similar equipment could be used to emulate the long distance network.
  - **Metrics**
    - Delay time T1, T2, T3 and T4 in msec
  - **Evaluation Methods**
    - The delay time should be measured by using a measurement tool that can measure the delay time on L2/L3 or media layer.
  - **Points to Verify**
    - Network delay time (T1, T2) as specified in the Figure 3.3-1 is less than 16.6 ms.
    - Network delay time (T3 + T4) as specified in the Figure 3.3-1 is less than 16.6 ms. (Note: this time should contain the time delay of network elements such as NW SW.)

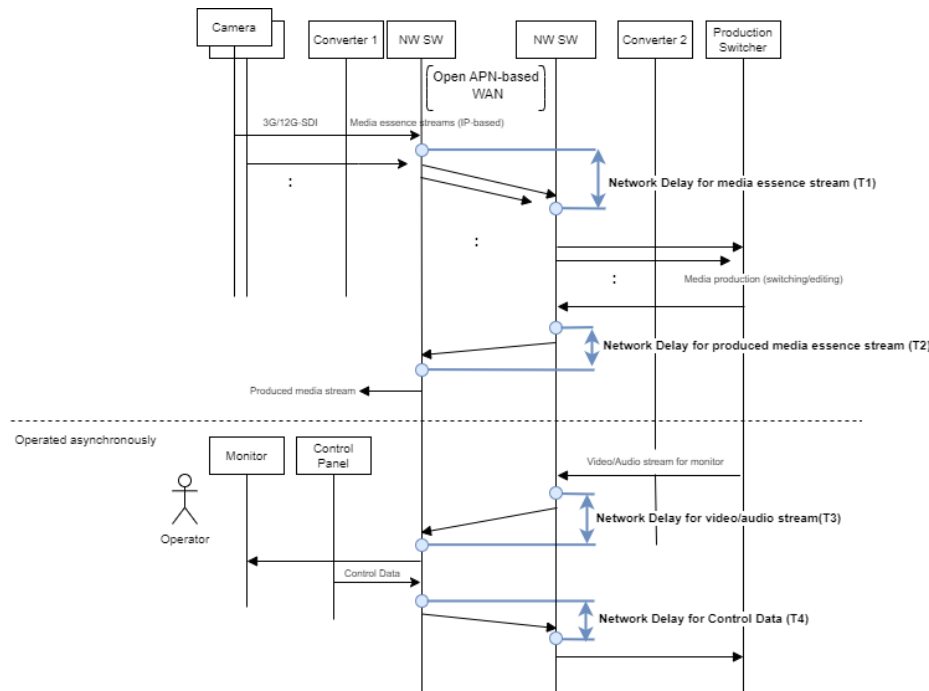

Figure 3.3-1 Simplified Sequence Chart for UC#3

- **Benchmark Testing: WAN availability**
  - **Prerequisites**
    - PoC Conductor designs the WAN configuration utilizing Open APN that satisfies the key requirements based on the availability information of NW and NW equipment.
    - The WAN link is established between a Broadcast Station and a Remote Site. All devices and nodes are running and Operator can conduct the Remote Media Production.
  - **Metrics**
    - Downtime (meantime to repair) in msec  
 Note: The measurement of availability requires long-time and statistical measurements. Therefore, it is not an effective way to measure it in this PoC activity. Instead, the downtime should be measured by intentionally causing a communication failure in WAN section which is designed considering the availability requirement.
  - **Benchmark Method**
    - PoC Conductor should measure the downtime of the WAN on the proposed system by making the WAN link down. If a redundant network is used, it should be measured when one of the network links is down.
    - The downtime should be measured by using a measurement tool that can measure the downtime in L2/L3 or media layer. Instead of measuring the downtime, it is allowed to estimate the downtime from other metrics such as the number of dropped packets during the downtime.
  - **Points to Benchmark**
    - From the downtime, the number of dropped video frames that impacts on the live media production could be estimated. In the live media production, the downtime should be minimized to produce high-quality content while cost-effective solution is also needed for economic feasibility.
- **Benchmark Testing: System/Operation cost**
  - **Prerequisites**
    - (none)
  - **Metrics**
    - Resources required for media production that affects on the system and operation costs (e.g. media production resources and personnel costs and the required network resources such as the number of optical cables, information about their distance and bandwidth, network elements such as switches and transceivers.)

- **Benchmark Method**
  - Estimate the required resources for media production based on the Technology Evaluation Criteria as described in the UC document [1].
  - It is recommended to compare it with the case of media production on premises.
- **Benchmark Testing: Switching time (optional)**
  - **Prerequisites**
    - The WAN link is established between a Broadcast Station and a Media Production Center. All devices and nodes are running and Operator can conduct the Remote Media Production.
  - **Metrics**
    - The switching time (TS2-TS1) in msec, where TS1 is the time when the WAN link between a Event Venue and a Broadcast Station is down, and TS2 is the time when a WAN link is established between the Event Venue and a different Broadcast Station and it is ready to communicate.
  - **Benchmark Method**
    - Record the current time TS1
    - Send a request to release the path between the Media Production Center and the Broadcast Station to APN Controller or other system (or via Service Exposure Function of DCI system)
    - Send a request to allocate a path to APN Controller or other system (or via Service Exposure Function of DCI system) to establish a new path between the Media Production Center and a different Broadcast Station.
    - Record the time TS2 by monitoring or logging the path is established.

#### 4. Conclusion

This document explained the basic strategy of system architecture and design that utilize IOWN GF Technology to efficiently realize the Remote Media Production Use Case.

As explained in the section 1.2, this document covered 3 and 4 described in Section 1.1 Objective to engage early adopters in the broadcast industry. This document will be followed by Proof-of-Concept demonstrations and evaluation, to prove the validity of IOWN GF Technology and its effectiveness towards the Broadcast Industry.

## 5. Appendix A. References

[1] IOWN Global Forum, “Remote Media Production for Broadcast Industry Use Case”, [https://iowngf.org/wp-content/uploads/formidable/21/IOWN-GF-RD-Remote\\_Media\\_Production\\_Use\\_Case-1.0.pdf](https://iowngf.org/wp-content/uploads/formidable/21/IOWN-GF-RD-Remote_Media_Production_Use_Case-1.0.pdf)

[2] IOWN Global Forum, “Open All-Photonic Network Functional Architecture”, [https://iowngf.org/wp-content/uploads/formidable/21/IOWN-GF-RD-Open\\_APN\\_Functional\\_Architecture-2.0.pdf](https://iowngf.org/wp-content/uploads/formidable/21/IOWN-GF-RD-Open_APN_Functional_Architecture-2.0.pdf)

[3] IOWN Global Forum, “INNOVATIVE OPTICAL AND WIRELESS NETWORK GLOBAL FORUM VISION 2030 AND TECHNICAL DIRECTIONS”, [https://iowngf.org/wp-content/uploads/2023/03/IOWN\\_GF\\_WP\\_Vision\\_2030\\_2.0-2.pdf](https://iowngf.org/wp-content/uploads/2023/03/IOWN_GF_WP_Vision_2030_2.0-2.pdf)

[4] SOCIETY OF MOTION PICTURE AND TELEVISION ENGINEERS (SMPTE), “ST2110 Suite of Standards”, [SMPTE ST 2110 - Society of Motion Picture & Television Engineers](https://www.smpte.org/standards/ST-2110)

## 6. Appendix B. Terms and Definitions

| <b>Term</b>               | <b>Definition</b>  |
|---------------------------|--|
| Broadcast Station         | A facility that is equipped to broadcast television programs.  |
| Event Venue               | A venue where an event (e.g. football and concert) is conducted.   |
| Media Production Resource | A software or hardware that is used for media production.<br>(e.g. production switcher, editor, audio mixer)                         |
| Media Production Center   | A facility that has media production resources and has a functionality to allocate their resources to users who request to use them. |
| PoC Conductor             | A company or companies who conduct the PoC that is specified in PoC Reference section of this document.                              |
| Remote Office             | An office or a facility where an operator remotely controls media production resources.  |

## 7. Appendix C. Examples of Implementation Models

This section describes some examples of the implementation models for Open APN-based WAN and also describes some examples of redundant network configuration. These examples would help PoC Conductors to consider WAN configurations.

### 7.1. Open APN-based WAN

There could be three types of Open-APN based WAN as follows.

- End-to-End Open APN
  - 1. PtP APN
  - 2. PtMP APN
- Interconnection at the middle
  - 3. PtP APN + Interconnection + PtP APN
  - 4. PtP APN + Interconnection+ PtMP APN
- Cascade of Interconnection, especially for long-haul transmission
  - 5. PtP (or PtMP) APN + Interconnection + PtP APN + Interconnection +PtP (or PtMP) APN

Here, interconnection is located at C/O and aggregates/disaggregates traffic, so that optical path can be efficiently used by multiplexing multiple end-to-end traffic.

Table C-1 describes the overview of the examples and each of examples are described in Figure C-1 to C-5 based on UC#1. For other use cases, similar network pattern could be applied.

Table C-1 Overview of Implementation Model Examples

| # | Remote Office to C/O                            | C/O to C/O                                      | C/O to Broadcast Station   | Note  |
|---|---|---|--|---|
| 1 | PtP APN (Digital Coherent APN-T (100G or more)) |   |  | E2E optical path                                    |
| 2 | PtMP APN (e.g. XR Optics (25Gx4))               |   |  | E2E optical path but branch at Central Office (C/O) |
| 3 | PtP APN (Digital Coherent APN-T (100G))         | NA  | PtP APN (e.g. 25Gx4 IMDD APN-T)  | Aggregate at C/O                                    |
| 4 | PtP APN (Digital Coherent APN-T (100G))         | NA  | PtMP APN (50G/25G/10G TDM-based PON or XR Optics (25Gx4))                                    | Aggregate at C/O                                    |
| 5 | PtP APN (Digital Coherent APN-T (25G))          | PtP APN (Digital Coherent APN-T (100G or more)) | PtP APN (e.g. 25Gx4 IMDD APN-T) or PtMP APN (50G/25G/10G TDM-based PON or XR Optics (25Gx4)) | Aggregate/Disaggregate                              |

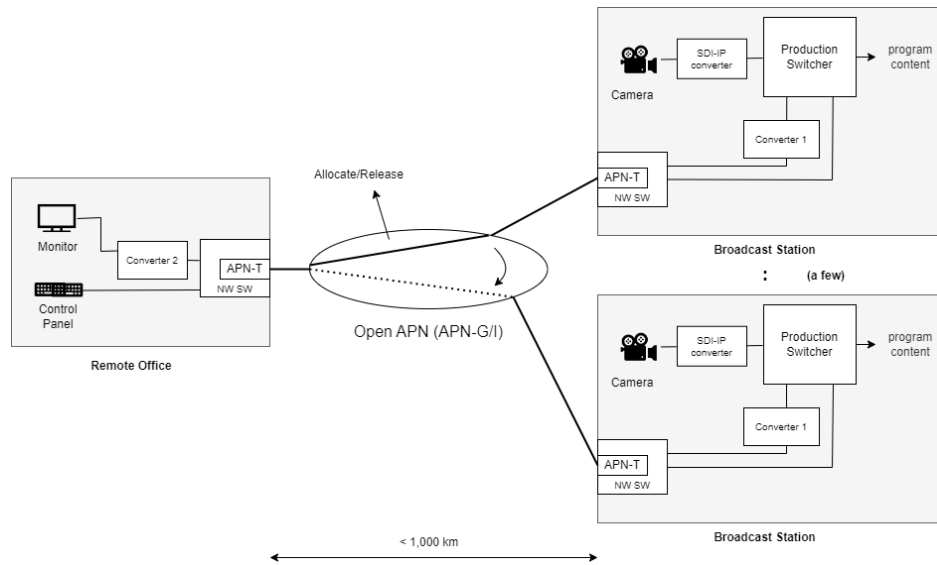

Figure C-1 An example of WAN configuration #1

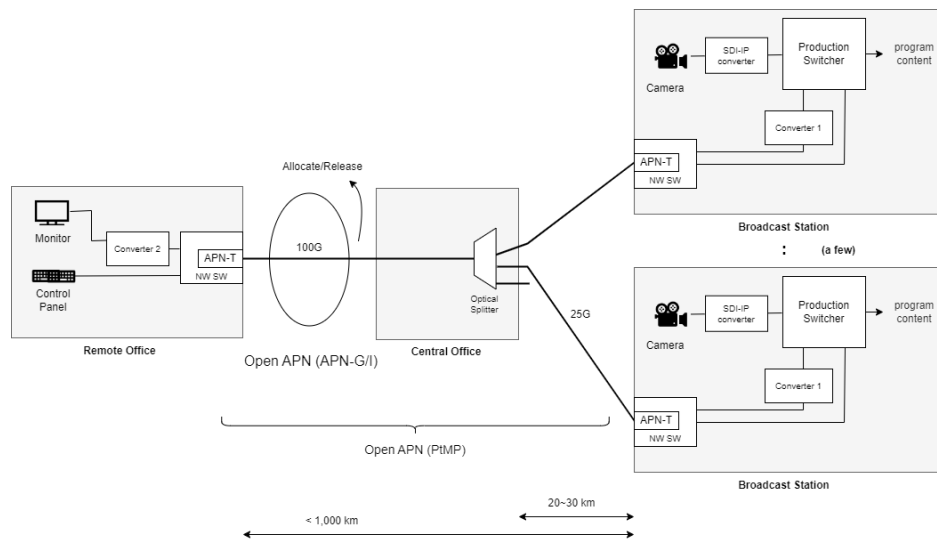

Figure C-2 An example of WAN configuration #2

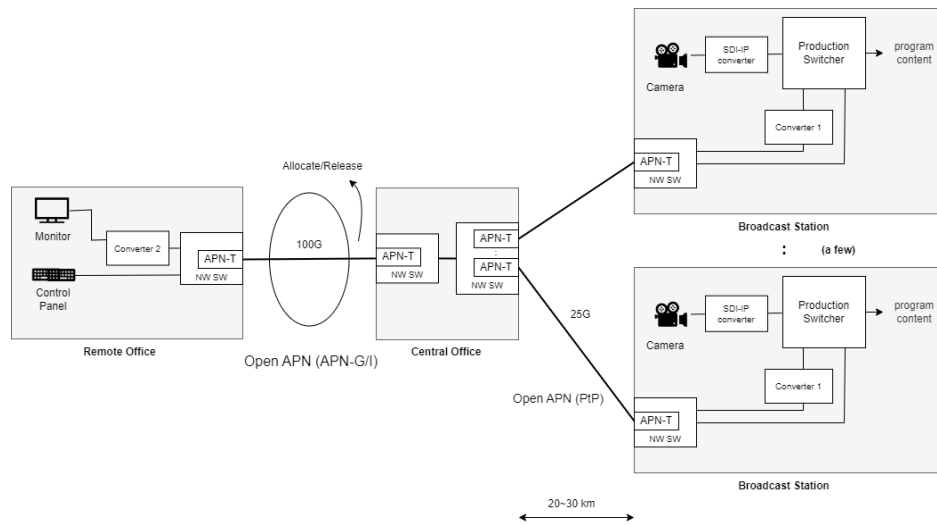

Figure C-3 An example of WAN configuration #3

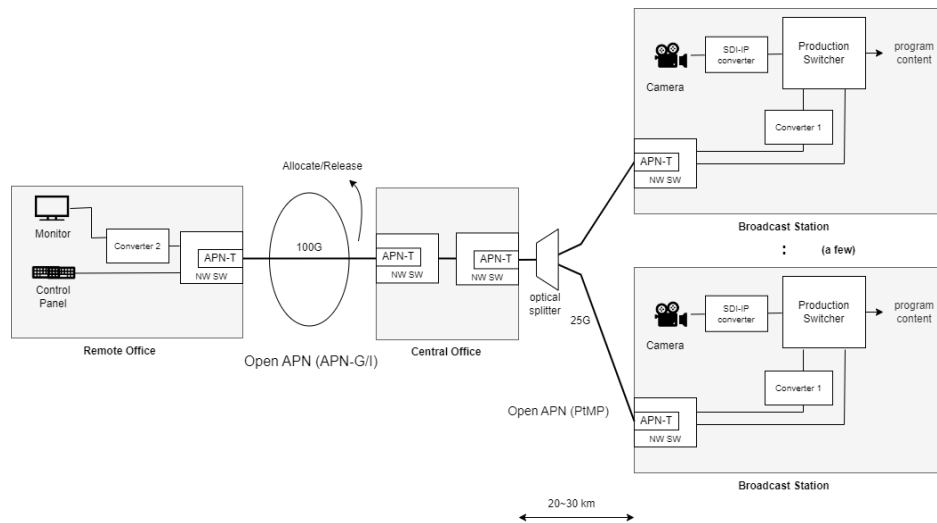

Figure C-4 An example of WAN configuration #4

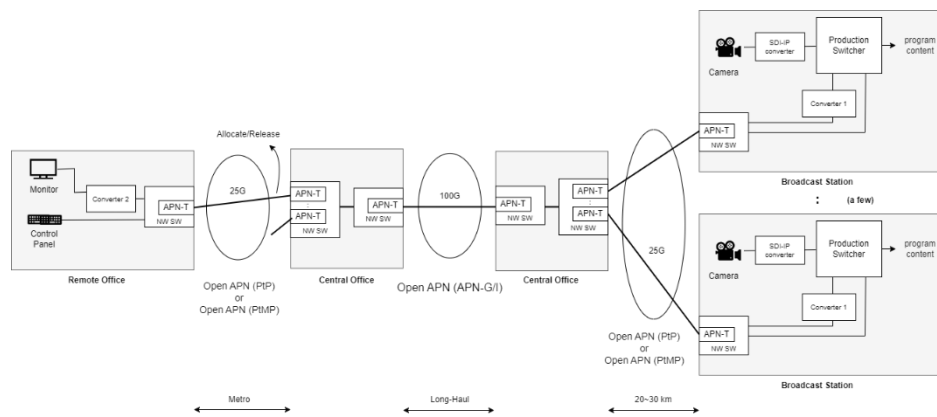

Figure C-5 An example of WAN configuration #5

Note that in all examples, NW SW can be muxponder or packetponder. Also two NW SWs at C/O can be implemented as a single NW SW.

## 7.2. Redundancy

Three examples are described in Figure C-6 to C-8.

One example is to switchover the path in Open APN when a failure occurs somewhere in Open APN. Figure C-6 shows the overview of this example.

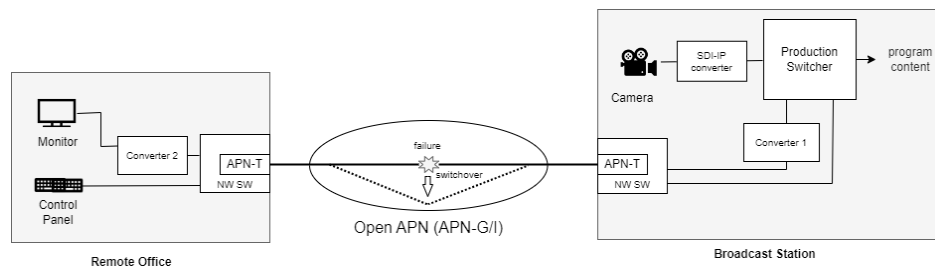

Figure C-6 Switchover in Open APN path

The second example is two redundant Open APN established between sites as shown in Figure C-7. Each site has two APN-T. Data are transmitted via one of Open APN path and another Open APN path is in hot standby state. When a failure occurs at the Open APN path where the data is transmitted, the NW switch switchover the data flow to the standby one.

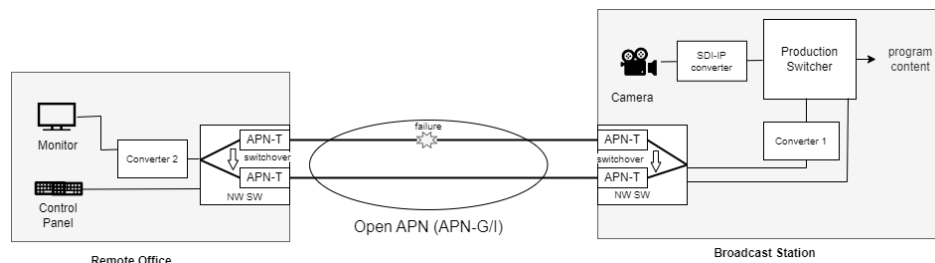

Figure C-7 Redundant APN

One more example is two Open APN path with NW switches as shown in Figure C-8. It switchover the path by L2/L3 switch or equipment that supports SMPTE ST2022-7.

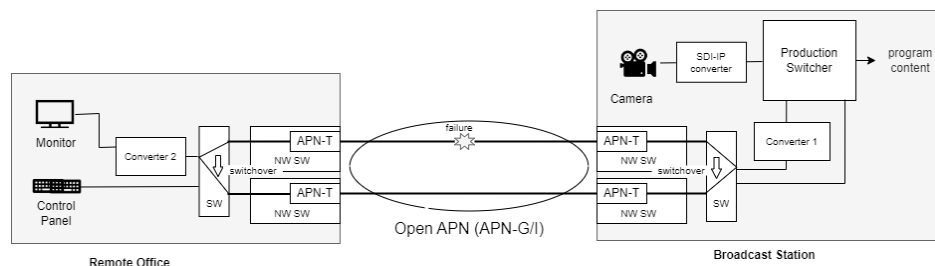

Figure C-8 Redundancy in L2/L3 or SMPTE ST2022-7

# History

| Revision | Release Date  | Summary of Changes |
|----------|---------------|--------------------|
| 1        | December 2024 | Initial Release    |